

IMPERIAL SHELVING - Double Entry Unit Legal Size, 36" and 48" Wide

Tennsco Corp., Dickson, TN 37056-1888 • (615) 446-8000

RETAIN INSTRUCTIONS FOR FUTURE REFERENCE!

Congratulations on your purchase of Imperial Shelving from **Tennsco**! Imperial shelving is designed for information users who demand instant records identification and easiest access. Available in 76" and 88" heights, Imperial open shelf files feature modular add-on construction, allowing your system to grow when your needs grow and adapt as your needs change.

Heavy gauge steel construction with baked on enamel finish assures years of trouble free service, even under the most demanding situations. Snap together assembly assures easy installation. The high density design is perfect for organizing and storing file folders, project envelopes, ring binders, literature, books, office supplies and more. And an optional reference shelf provides pull-out workspace for added convenience.

GENERAL SAFETY INFORMATION

Some parts may have sharp edges. CARE must be taken when handling various pieces to avoid injury. For safety, wear a pair of work gloves when assembling or performing any maintenance on shelving.

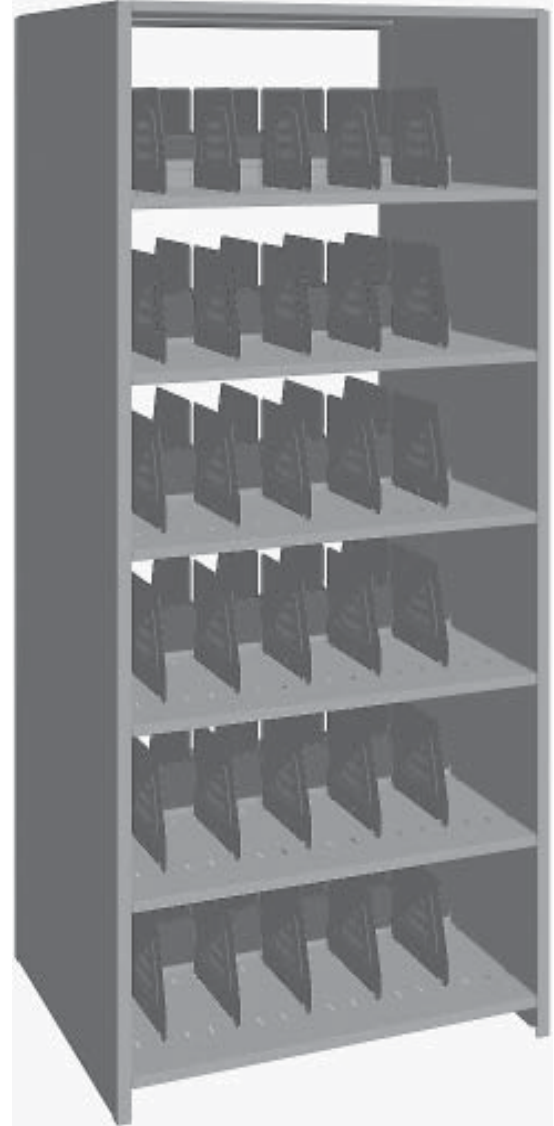

LIMITED WARRANTY

Tennsco warrants goods purchased hereunder to be free of defects in materials and workmanship for a period of one (1) year from the date of shipment, hereunder. This warranty shall not apply in the event goods are damaged as a result of misuse, abuse, neglect, accident, improper application, modification or repair by persons not authorized by Seller, where goods are damaged during shipment, or where the date stamps on the goods have been defaced, modified or removed. UNLESS CONSIDERED UNENFORCEABLE OR UNLAWFUL UNDER APPLICABLE LAW:

- a. ALL IMPLIED WARRANTIES, INCLUDING BUT NOT LIMITED TO WARRANTIES OR MERCHANTABILITY AND FITNESS FOR A PARTICULAR PURPOSE ARE HEREBY EXCLUDED:
- b. BUYERS REMEDY, IF ANY, FOR ANY DEFECTIVE GOODS SHALL BE LIMITED TO A REFUND BY SELLER OR REPLACEMENT OF THE GOODS AT SELLER'S OPTION, AND SHALL IN NO EVENT INCLUDE DAMAGES OF ANY KIND, WHETHER INCIDENTAL, CONSEQUENTIAL OR OTHERWISE.

NO GOODS ACCEPTED FOR RETURN WITHOUT PRIOR APPROVAL. Seller shall have the right to inspect any goods claimed to be defective at Buyers place of business or require Buyer to return the goods to Seller for inspection on Seller's premises. Transportation charges covering returned goods will be borne by Seller only if such goods are proven to be defective, are covered by this warranty and are returned within the warranty period stated above.

TENNSCO CORP., P.O. BOX 1888, DICKSON, TN 37056-1888
(615) 446-8000 (800) 251-8184

ASSEMBLY OF IMPERIAL DOUBLE ENTRY FILES

Tools Needed: A rubber mallet is helpful for seating shelf supports. Requires one or two people for assembly. The first seven steps are easier with two people assembling. Approximate assembly time: 20 to 40 minutes.

1. Unpack all items and carefully compare the items you received with the packing list on the back page.
2. Determine whether you will be assembling a single unit, or multiple units joined together. For a single unit, use two closed "L" uprights (Ref. No. 1a). For multiple units, use one "L" upright and one open "T" upright (Ref. No. 1b).

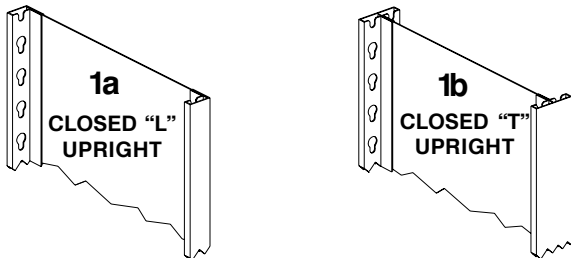

3. Examine the slots on the two uprights you have selected. When an upright is standing up on end, the narrow part of the keyhole slots should be toward the floor, while the wide part should be toward the top.

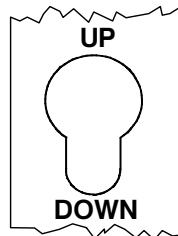

4. After determining the top from the bottom of the upright, attach a plastic foot (Ref. No. 10 or 11) to the bottom of each upright by pressing it into place. Note the difference at right between a foot for an "L" upright and a foot for a "T" upright.

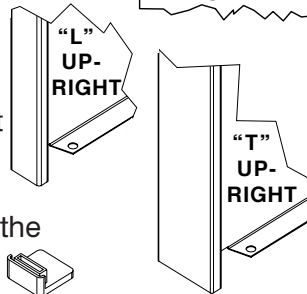

5. Lean one "L" upright against a wall, and temporarily place one shelf support (Ref. No. 2) at approximately eye level to properly space the uprights. Make sure both rivets on the shelf support are fully inserted into the keyhole slots, and are firmly seated at the bottom of the keyhole as shown in step 6.

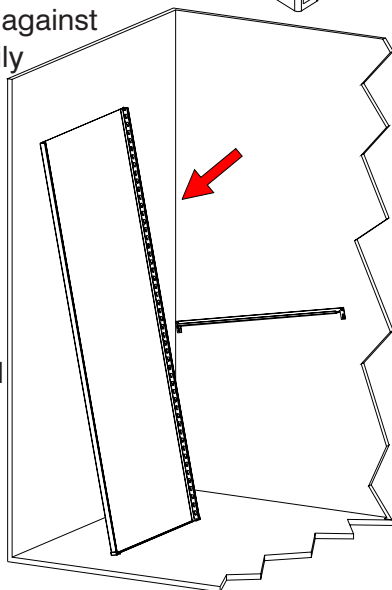

6. **PLEASE NOTE:** To firmly seat shelf supports, make sure both rivets are fully inserted in the keyhole slots, and firmly seated in the bottom of the slot. A rubber mallet can be helpful in accomplishing this. **Supports are not fully seated unless you can see an open space through the hole in the shelf support as shown below.**

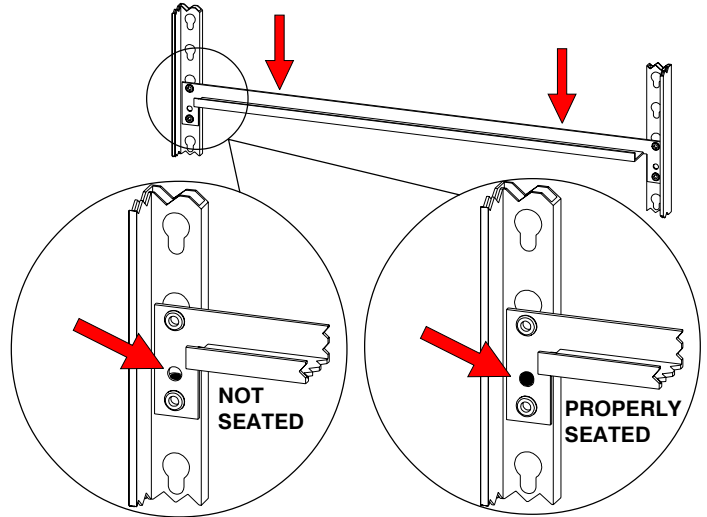

7. Hold a second "L" upright (or a "T" upright if you are assembling multiple units) approximately 36" or 48" away, depending on the width of your unit. Pull the first upright away from the wall using the shelf support you attached in step 5, and insert the other end of the shelf support into the second upright. **NOTE: Take care not to let the uprights fall, as they are not stable until step 8 is completed.**

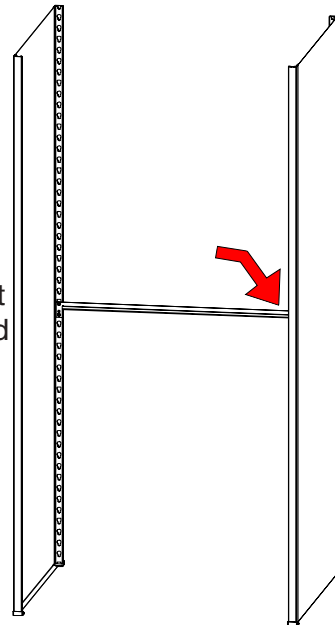

8. Place a shelf support at the rear of the unit in the bottom keyhole slots, in the same way you placed the shelf support in steps 5 through 7. Then, place a second shelf support at the bottom front of the unit.

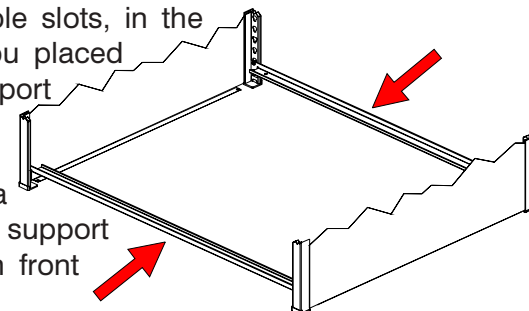

9. Place a shelf reinforcement (Ref. No. 7) across the two shelf supports. The slot in each end of the shelf reinforcement should fit over the ridge of the shelf support.

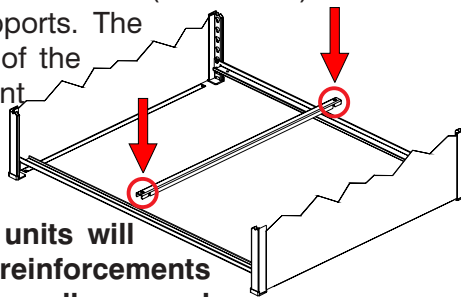

NOTE: 48" wide units will use TWO shelf reinforcements per shelf level, equally spaced.

10. Attach one center stop (Ref. No. 3) to one of the slotted shelves (Ref. No. 4) by aligning the three holes in the center stop flange with the holes in the center of the shelf. Attach with three 10-24 x 1/2" bolts and nuts (Ref. Nos. 8 & 9).

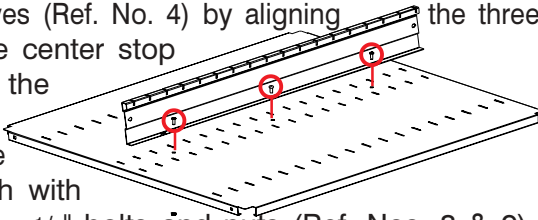

11. Place the shelf, with the center stop attached, onto the unit by lowering it over the top of the shelf supports. The edges of the shelf should fit over the top of the shelf supports, hiding them from view.

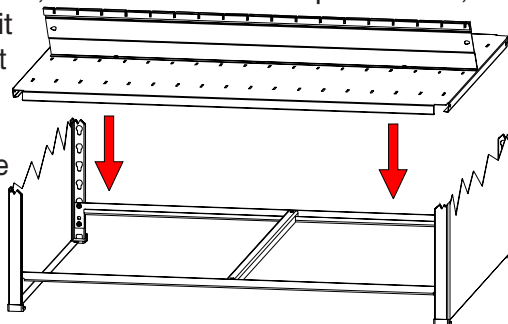

12. Continue the assembly by placing supports, shelves, reinforcements and center stops as described in steps 8 through 11. The recommended spacing between shelves is twelve inches, which equals six open keyhole slots between supports. If necessary, move the temporarily placed reinforcement from step 7. **Save the plain shelf (without slots) for unit TOP.**

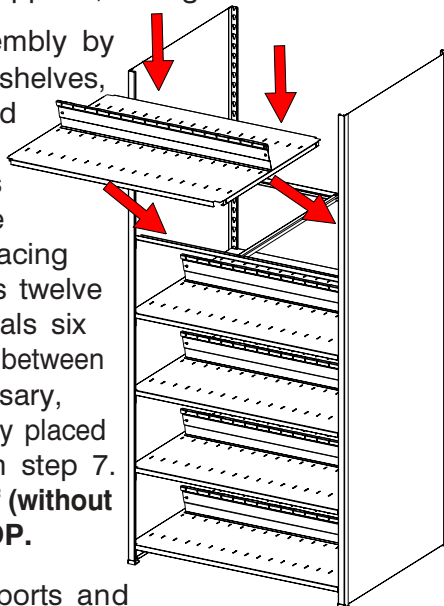

13. The top shelf supports and top shelf (Ref. No. 5) should be installed flush with the upright top. Note that the top shelf has no divider slots. No shelf reinforcements are needed under top shelf.

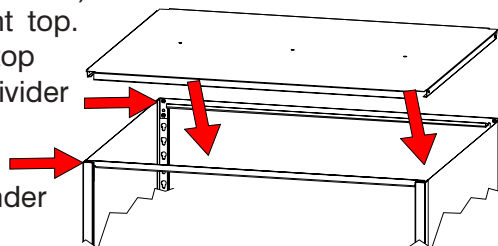

14. Insert shelf dividers (Ref. No. 6) by placing dividers into slots on shelf and then hooking into the slot in the back stop. You have been provided with enough dividers for ten per shelf level (five on each side of the shelf), but these can be placed in whatever position most suits your needs.

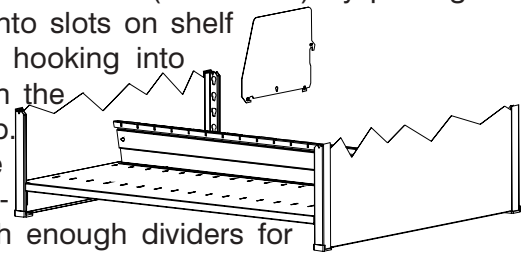

15. If you are assembling only a single unit, assembly is now complete (shown below left). If you are assembling multiple units joined together, your starter unit should have been assembled with a "T" upright (shown below right), as described in step two. Continue with step 16.

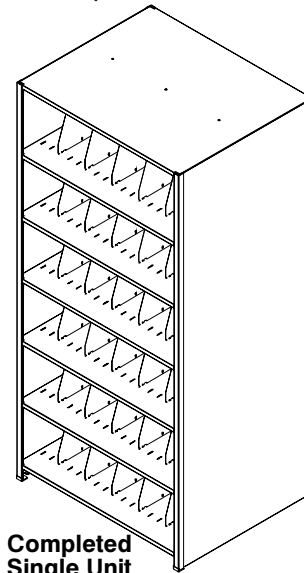

Completed Single Unit

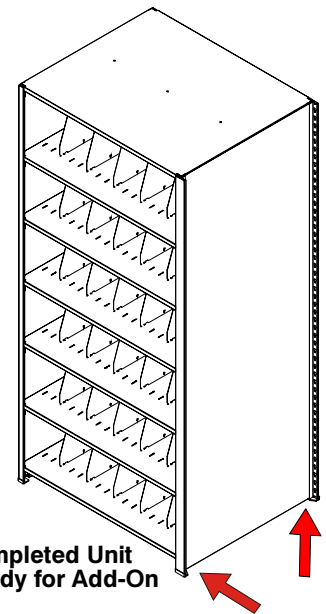

Completed Unit Ready for Add-On

16. Repeat steps 5 through 14, adding the shelf supports to the "T" upright already in place on the unit.

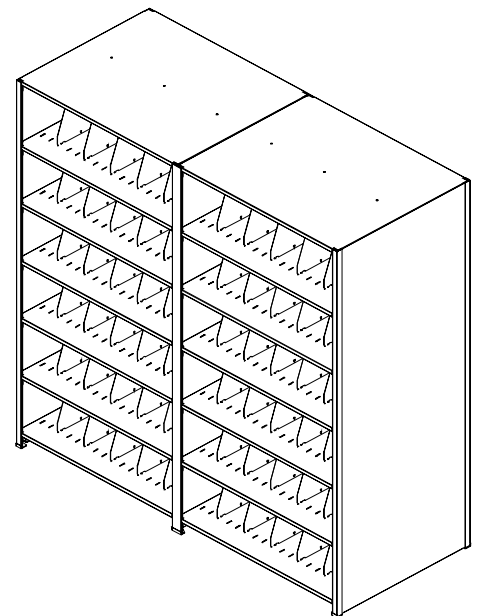

PACKING LIST

ITEM NO.	DESCRIPTION	PART NO.	3630 UNITS				4830 UNITS			
			36W x 30D x 76H 6 openings		36W x 30D x 88H 7 openings		48W x 30D x 76H 6 openings		48W x 30D x 88H 7 openings	
			QUANTITY		QUANTITY		QUANTITY		QUANTITY	
			STARTER 3076PC	ADD-ON 3076AC	STARTER 3088PC	ADD-ON 3088AC	STARTER 307648PC	ADD-ON 307648AC	STARTER 308848PC	ADD-ON 308848AC
1a	Closed "L" Upright	3076LC	2	-	-	-	2	-	-	-
1a	Closed "L" Upright	3088LC	-	-	2	-	-	-	2	-
1b	Closed "T" Upright	3076TC	-	1	-	-	-	1	-	-
1b	Closed "T" Upright	3088TC	-	-	-	1	-	-	-	1
2	Shelf Support	TS-3614	14	14	16	16	-	-	-	-
2	Shelf Support	TS-4811	-	-	-	-	14	14	16	16
3	Center Stop	CS-36	6	6	7	7	-	-	-	-
3	Center Stop	CS-48	-	-	-	-	6	6	7	7
4	Slotted Shelf	TQD2-3630	6	6	7	7	-	-	-	-
4	Slotted Shelf	TQD2-4830	-	-	-	-	6	6	7	7
5	Plain Shelf	T2-3630	1	1	1	1	-	-	-	-
5	Plain Shelf	T2-4830	-	-	-	-	1	1	1	1
6	Divider	FD-1108	60	60	70	70	60	60	70	70
7	Shelf Reinforcement	TR-30	6	6	7	7	12	12	14	14
8	10-24 x 1/2" Bolt	Available Locally	18	18	21	21	18	18	21	21
9	10-24 x 1/2" Hex Nut	Available Locally	18	18	21	21	18	18	21	21
10	Plastic "L" Foot	LTNF-L	4	-	4	-	4	-	4	-
11	Plastic "T" Foot	LTNF-T	-	2	-	2	-	2	-	2

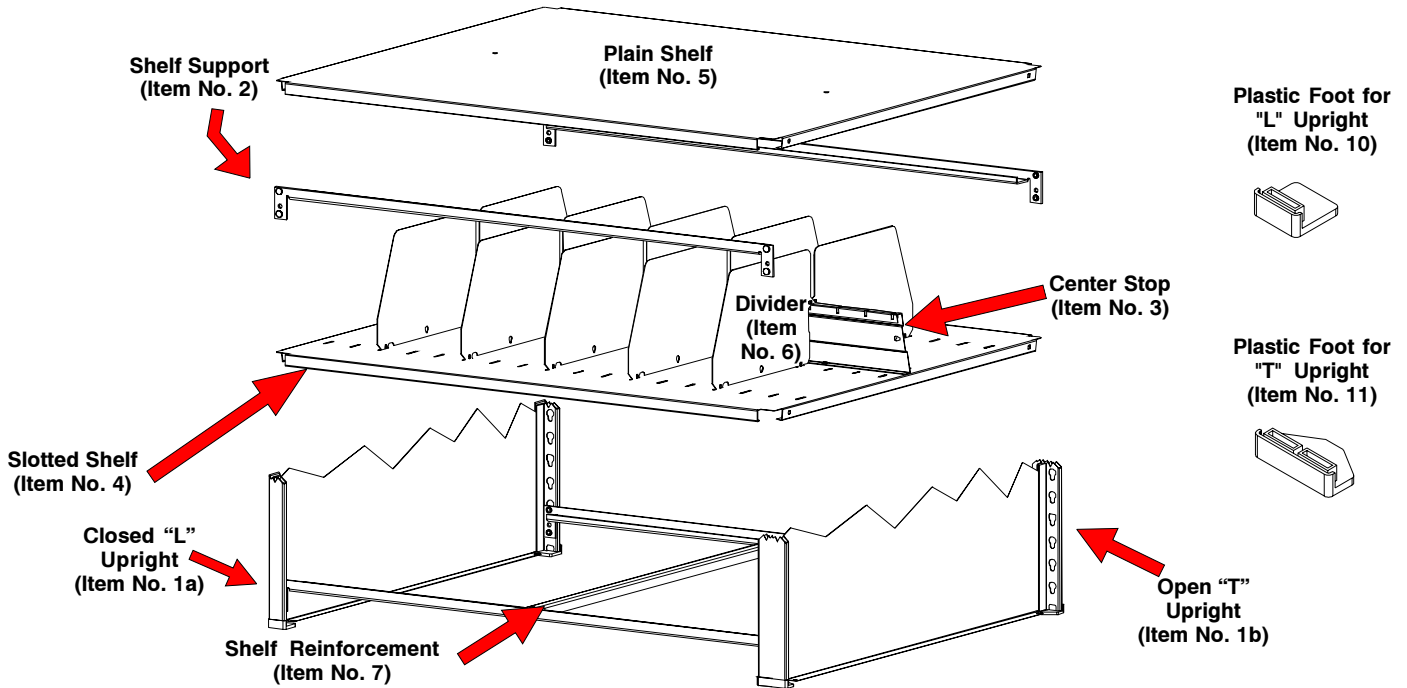

Tennsco makes every effort to ensure that all units ship complete with all parts and arrive undamaged. However, should your unit contain missing or damaged parts, replacements may be obtained directly from Tennsco. To obtain proper replacement parts, follow the instructions below or fill out the form at www.tennsco.com/partsorder.html.

TO OBTAIN PROPER REPLACEMENT PARTS, PLEASE PROVIDE THE FOLLOWING INFORMATION:

- Model Number
- Description of part(s) needed and part number(s) as shown in Parts List (above)
- Color (Sand)
- Was item missing, or was it damaged?
- Purchase Date
- Your company name
- Contact person's name
- Who the product was purchased from

Tennsco Corp., P.O. Box 1888, Dickson, TN 37056-1888 Voice: (800) 251-8184 Fax: (800) 722-0134
If requesting parts by telephone, ask for customer service and have as much of the above information ready as possible.