

JUMBO STORAGE CABINET

Model J2478A (consists of J478 & J24S)

Tennsco Corp., Dickson, TN 37056-1888 ♦ (615) 446-8000

Be Sure To Save This Instruction Sheet For Future Reference!

Congratulations on your purchase of a Jumbo storage cabinet from Tennsco! The Model J-2478A Jumbo Cabinet is 48"w x 24"d x 78" tall, providing abundant storage space. Our cabinets are rigidly constructed to give you years of dependable and efficient service. Nylon lock-bar guides ensure smooth, quiet operation. A locking handle with two keys provides a three-point locking system for added security. Sturdy adjustable shelves provide exceptional strength — up to 400 lbs per shelf, evenly distributed. And our baked-on powder finish adds even more durability.



GENERAL SAFETY INFORMATION: Some parts may have sharp edges. Care must be taken when handling various pieces to avoid injury. Wear work gloves when assembling or performing maintenance on cabinet.

LIMITED WARRANTY

Tennsco warrants goods purchased hereunder to be free of defects in materials and workmanship for a period of one (1) year from the date of purchase, hereunder. This warranty shall not apply in the event goods are damaged as a result of misuse, abuse, neglect, accident, improper application, modification or repair by persons not authorized by Seller, where goods are damaged during shipment, or where the date stamps on the goods have been defaced, modified or removed. UNLESS CONSIDERED UNENFORCEABLE OR UNLAWFUL UNDER APPLICABLE LAW:

- a. ALL IMPLIED WARRANTIES, INCLUDING BUT NOT LIMITED TO WARRANTIES OF MERCHANTABILITY AND FITNESS FOR A PARTICULAR PURPOSE ARE HEREBY EXCLUDED.
- b. BUYERS REMEDY, IF ANY, FOR DEFECTIVE GOODS SHALL BE LIMITED TO A REFUND BY SELLER OR REPLACEMENT OF THE GOODS AT SELLER'S OPTION, AND SHALL IN NO EVENT INCLUDE DAMAGES OF ANY KIND, WHETHER INCIDENTAL, CONSEQUENTIAL OR OTHERWISE.

NO GOODS ACCEPTED FOR RETURN WITHOUT PRIOR APPROVAL. Seller shall have the right to inspect any goods claimed to be defective at Buyer's place of business or require Buyer to return the goods to Seller for inspection on Seller's premises. Transportation charges covering returned goods will be borne by Seller only if such goods are proven to be defective, are covered by this warranty and are returned within the warranty period stated above.

Mailing Address: **TENNSCO CORP.**
P.O. Box 1888
Dickson, TN 37056-1888
(615) 446-8000 (866) 446-8686 (toll free)
www.tennsco.com

Shipping Address: **TENNSCO CORP.**
201 Tennsco Drive
Dickson, TN 37055
(615) 446-8000 (866) 446-8686 (toll free)
www.tennsco.com

Step By Step Cabinet Assembly Instructions

(APPROXIMATE ASSEMBLY TIME: 2 people, 25 to 45 minutes)

TOOLS REQUIRED: A free 11/32" nutdriver is included with each Tennsco cabinet. You will also need a flathead screwdriver and a hammer.

1. Before beginning assembly, compare the parts you have received against the parts list on the back cover to ensure that you have all the necessary pieces.

2. Place back panels on a smooth surface, making sure that the flanges of both panels are facing up. Overlap the right panel over the left panel. After aligning the holes, bolt the two panels tightly together with seven bolts and nuts.

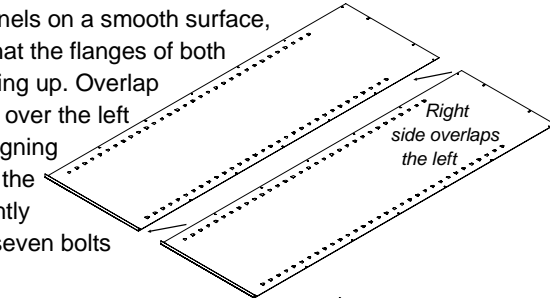

3. Attach the left side to the back by placing flange (A) around the back and bolting tightly together with seven bolts and nuts. Be sure that all shelf adjustment strips (B) point in the same direction.

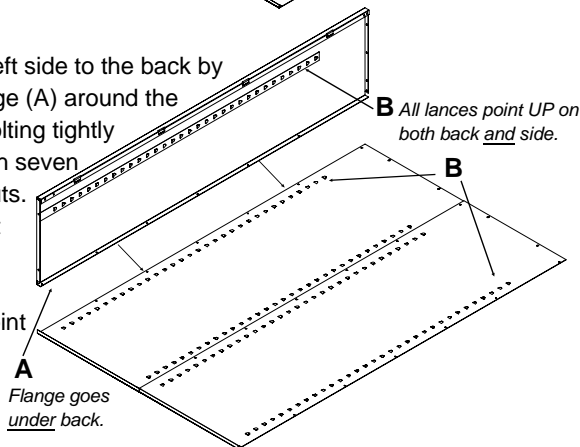

4. Insert bolts into the outside holes on the header portion of the top (two on each end as shown in Inset A). Attach the nuts, but do not tighten; the bolt heads will later be inserted into the keyhole slots of the sides, as shown in Inset B.

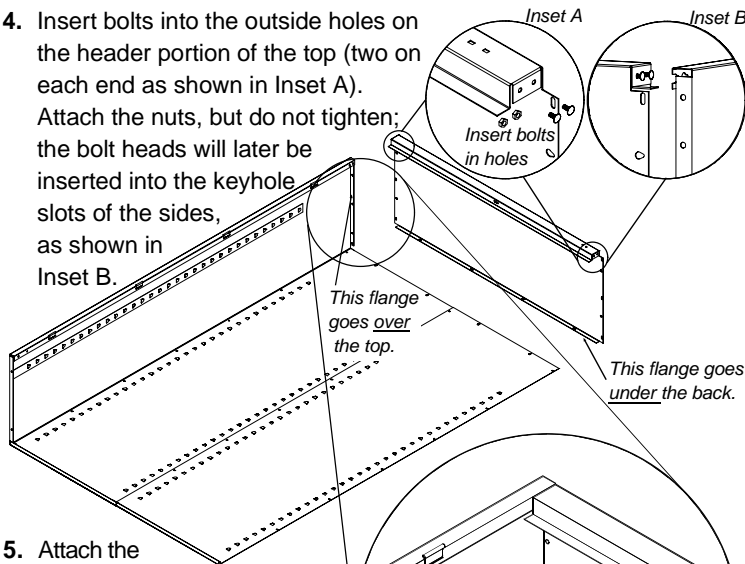

5. Attach the top to the back and left side by inserting the bolt heads (which you installed in step 4) into the large end of the keyhole slots, then sliding them securely into the smaller end. Be sure that the back flange on the top overlaps on the outside of the back, while the flange on the side panel fits over the left edge of the cabinet top as illustrated above. Attach four bolts and nuts through the holes in the back, and three bolts and nuts down each side. Tighten all bolts and nuts securely, including the four bolt heads which you loosely attached in step 4.

6. Attach right side to back in the same manner as you did in step 3, making sure that the side flange is around the back and the top flange is over the top. As before, be sure that all shelf adjustment strips point in the same direction. Attach three bolts and nuts across the top, and seven bolts and nuts down the side panel.

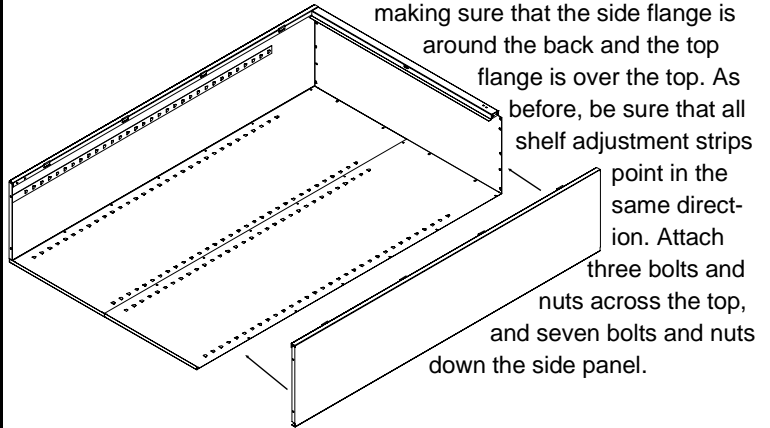

7. Insert bolts into the outside holes on the sill (two on each end). Attach the nuts, but do not tighten. Place the sill between the sides at the front of the cabinet, inserting the loose bolt heads into the two keyhole slots on each side. Make sure the bolt heads are fully pulled down into the bottom of the keyhole slots, as shown at right. Securely tighten the four bolt heads.

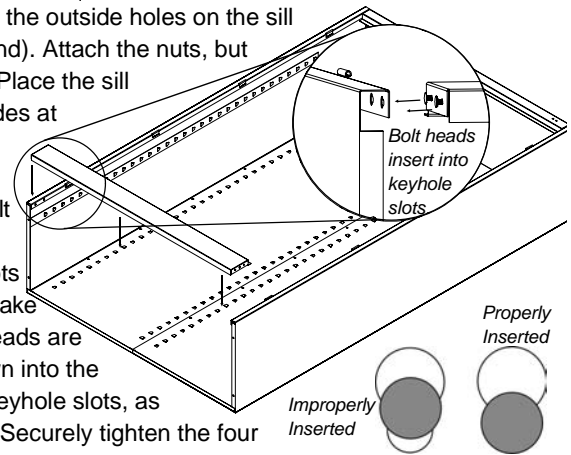

8. Place a shelf into the bottom lances, located on the back and sides of the unit. The flange on the sill will be just in front of the shelf.

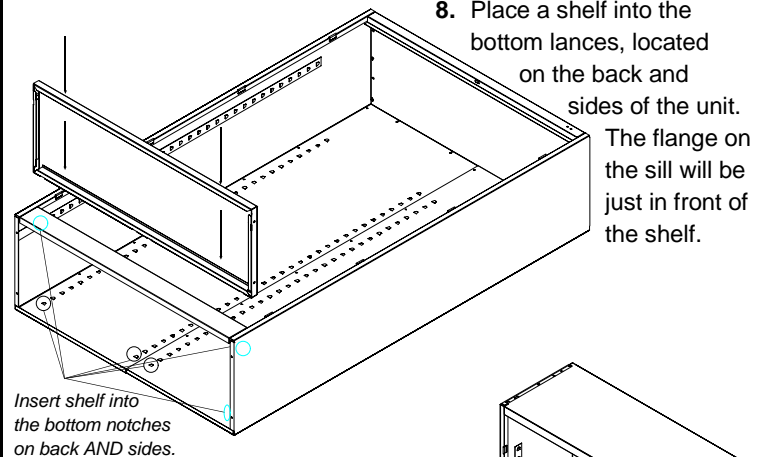

9. Using two people, set unit upright and insert the remaining shelves at the desired levels. Be sure that the edge with no slots is toward the cabinet front. The slots on the other three sides will fit over the lances on the cabinet walls, which will hold the shelf in place. It is helpful to have two people present to insert the shelves to be sure that all lances are engaged.

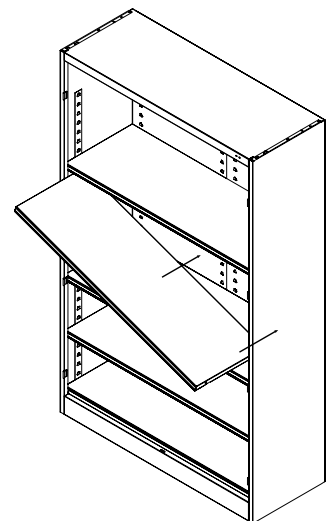

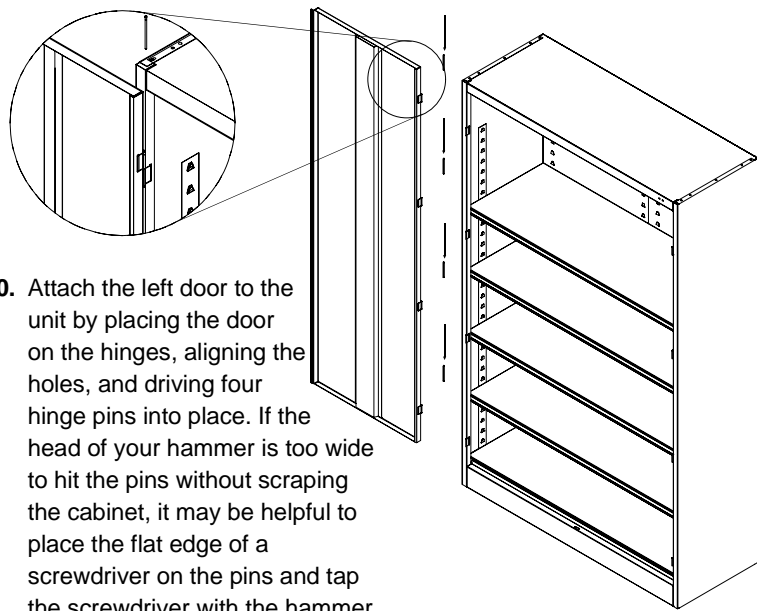

10. Attach the left door to the unit by placing the door on the hinges, aligning the holes, and driving four hinge pins into place. If the head of your hammer is too wide to hit the pins without scraping the cabinet, it may be helpful to place the flat edge of a screwdriver on the pins and tap the screwdriver with the hammer.

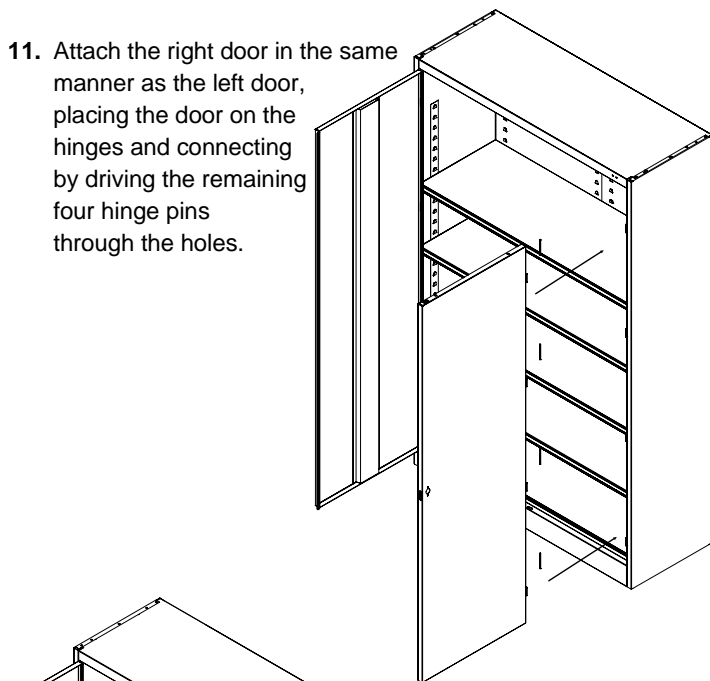

11. Attach the right door in the same manner as the left door, placing the door on the hinges and connecting by driving the remaining four hinge pins through the holes.

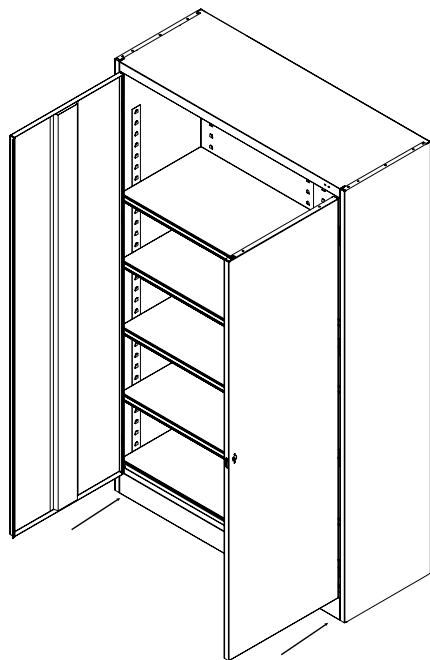

12. Adjust the levelers underneath the front of the unit to ensure that the cabinet is level. If the cabinet is not level, the doors will not align properly.

13. Your cabinet assembly is now complete except for handle and locking mechanism installation. See next column for handle and lock-bar attachment.

Handle/Locking System Installation Instructor

1. Place locking handle on right hand door and fasten with two slotted bolts with lockwashers.

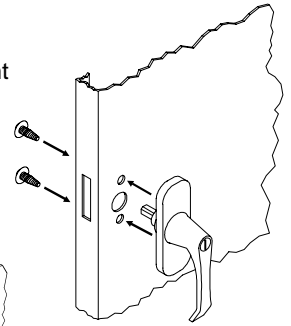

2. Turn handle to open position and place locking cam over square shank of door handle with latch facing downward.

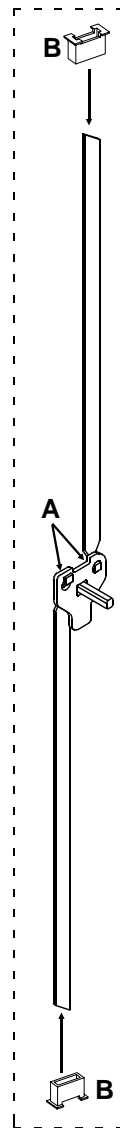
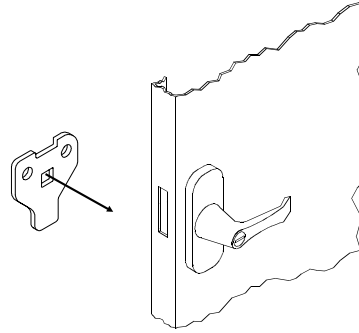

3. With handle still in open position, hook locking bars to locking cam (A). Then, hold lock bars in position while sliding nylon lock bar guide inserts over lock bar ends and through door slots (B).

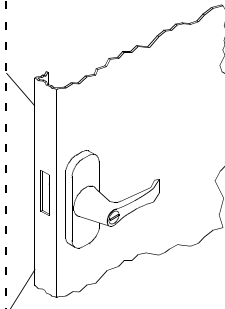

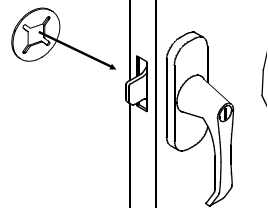

4. Place locking cam retainer over square shank of right door handle and tap on edges with hammer until retainer sits firmly against the locking cam.

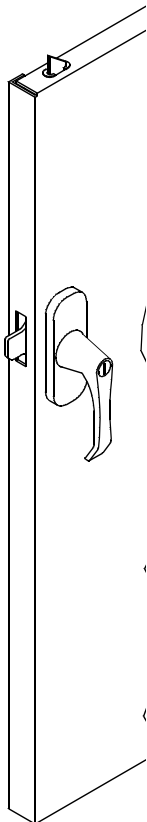

5. Attach dummy handle to left door using the two included screws.

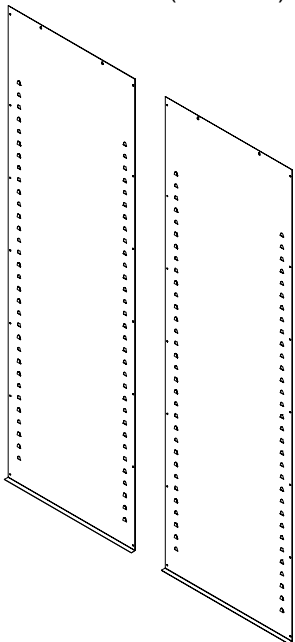
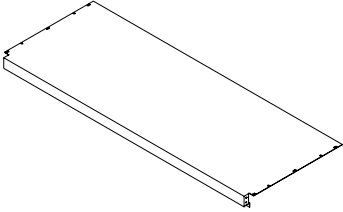
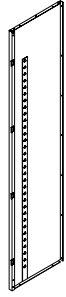
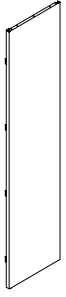
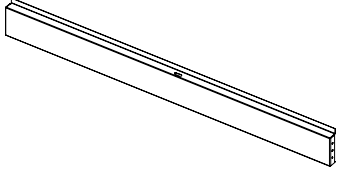
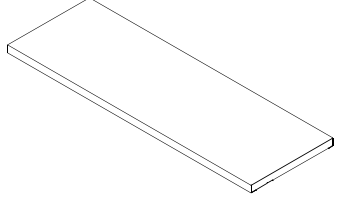
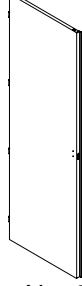
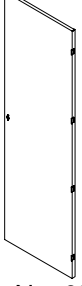
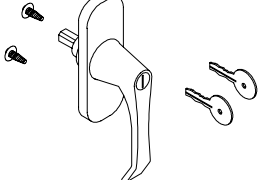
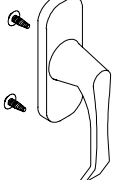
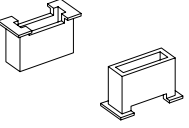
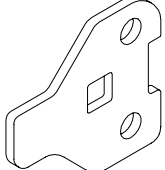

PARTS LIST

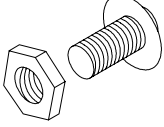
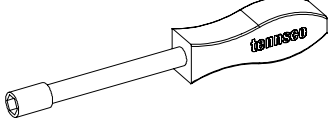
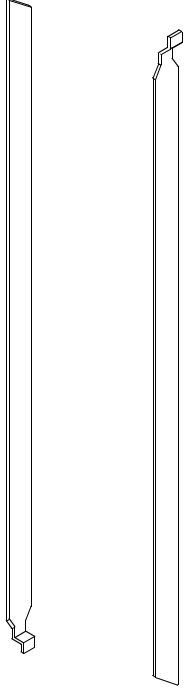
<p>Back Panel (2 Pieces)</p>  <p>(Part No. 055BA)</p>	<p>Top with Header (1 Piece)</p>  <p>(Part No.056TO)</p>	<p>Left Side Panel (1 Piece)</p>  <p>(Part No. 056LS)</p>	<p>Right Side Panel (1 Piece)</p>  <p>(Part No. 056RS)</p>
<p>Sill (1 Piece)</p>  <p>(Part No. 055SI)</p>	<p>Shelf (5 Pieces)</p>  <p>(Part No. 307)</p>	<p>Left Door (1 Piece)</p>  <p>(Part No. 056LD)</p>	<p>Right Door (1 Piece)</p>  <p>(Part No. 056RD)</p>
<p>Locking Handle w/Keys & Hardware (1 Set)</p>  <p>(Part No. 944LH)</p>	<p>Dummy Handle with Hardware (1 Set)</p>  <p>(Part No. 043DH)</p>	<p>Lock Bar Guide Insert (2 Pieces—Nylon)</p>  <p>(Part No. 944GI)</p>	<p>Locking Cam (1 Piece)</p>  <p>(Part No. 944LC)</p>
<p>Hinge Pin (8 Pieces)</p>  <p>(Part No. 944HP)</p>	<p>Cam Retainer (1 Piece)</p>  <p>(Part No. 944CR)</p>	<p>Bolts #8-32 x 3/8" (39 Pieces) Nuts #8-32 (39 Pieces)</p>  <p>(Available Locally)</p>	<p>Wrench/Screwdriver Tool</p>  <p>(Part No. TOOL-2)</p>
<p>Lock Bars (2 Pieces)</p>  <p>(Part No. 043LB)</p>			

Tensco makes every effort to ensure that all units ship complete with all parts and arrive undamaged. However, should your unit contain missing or damaged parts, replacements may be obtained directly from Tensco. To obtain proper replacement parts, follow the instructions below, or fill out the form at: www.tensco.com/partsorder.html

TO OBTAIN PROPER REPLACEMENT PARTS, PLEASE PROVIDE THE FOLLOWING INFORMATION:

- Model Number (J2478A)
- Color
- Your company name
- Purchase Date
- Who product was purchased from
- Contact person's name
- Description of part(s) needed and part number(s) as shown in Parts List (above)

Tensco Corp., P.O. Box 1888, Dickson, TN 37056-1888 Voice: (866) 446-8686 (toll free) Fax: (800) 722-0134
If requesting parts by telephone, ask for customer service and have as much of the above information ready as possible.