



**ADD-A-TRACK LATERAL SYSTEM  
FOR USE WITH L&T SHELVING**

Tennsco Corp., Dickson, TN 37056-1888 • (615) 446-8000

**RETAIN INSTRUCTIONS FOR FUTURE REFERENCE!**

**PART LIST FOR ADD-A-TRACK**

REF. NO.	DESCRIPTION	QUANTITY
1	Leveling Screw <sup>5</sup> / <sub>16</sub> -18 X 1"	16
2	Track Assembly	4
3	Floor Plate	8
4	Roll Pin	2
5	Track Splice Channel	2
6	10-32 x 1 <sup>3</sup> / <sub>4</sub> Hex Head Screw	2
7	10-32 Hex Nut	2
8	Rubber Bumper	4
9	Deck Cover ( for Track Spreader Panel )	2
10	Track Spreader Panel	2
11	Deck Cover ( for Track Assembly )	2
12	Ramp Plate	2
13	Track End Plate	4
14	End Plate Angle	4
15	#14 Machine Screw	8
16	Top Track	4
17	8-32 x <sup>1</sup> / <sub>2</sub> Hex Head Machine Screw	10
18	8-32 Plate Nut	10
19	Roller Guide Channel	2
20	Base of Upright on L&T unit	*not included with ADD-A-TRACK system
21	Mobile Carriage	2
22	<sup>1</sup> / <sub>4</sub> -20 x 1 <sup>1</sup> / <sub>2</sub> Hex Head Bolt	12
23	<sup>1</sup> / <sub>4</sub> -20 Hex Nut	12
24	Stabilizer Support Angle for front unit	1
25	Stabilizer Roller Bracket Assembly for middle unit	1
26	Stabilizer Cover/Roller Bracket Assembly	1
27	<sup>1</sup> / <sub>4</sub> -20 x <sup>1</sup> / <sub>2</sub> Bolt	4

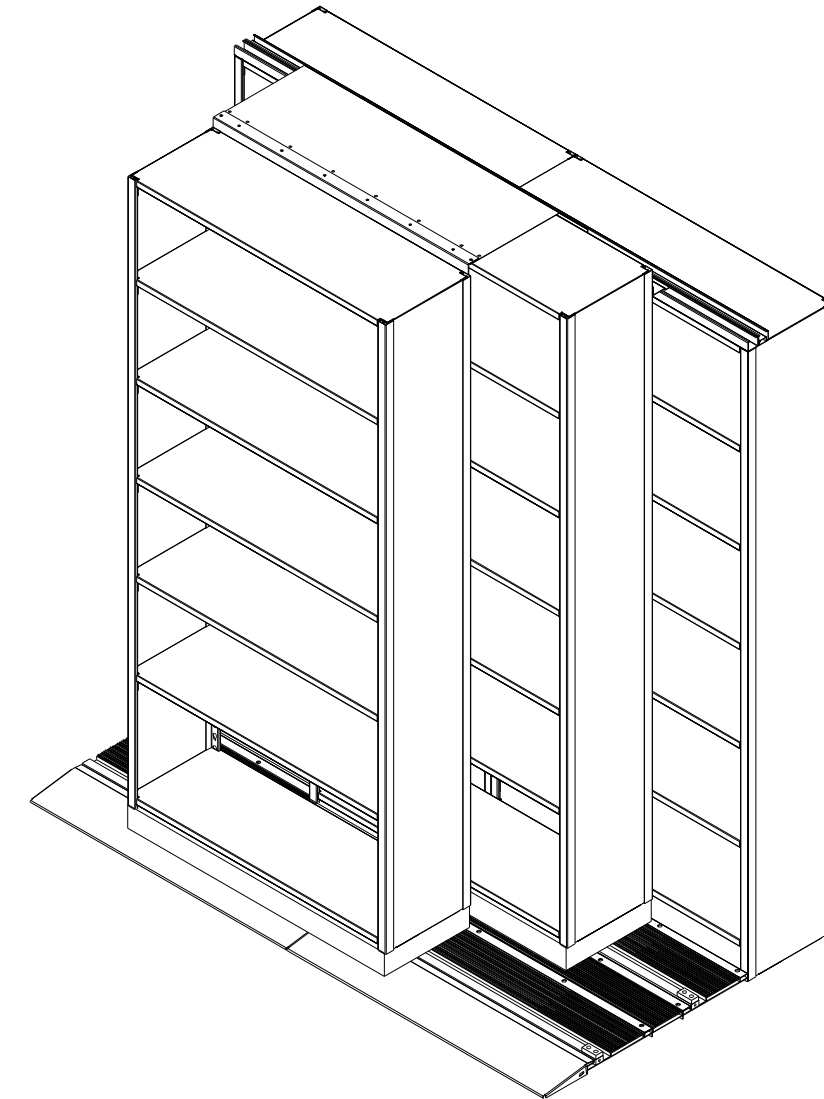

**We make every effort to ensure that all units ship complete and arrive undamaged. However, should your unit contain missing or damaged parts, replacements may be obtained directly from us. To obtain proper replacement parts, follow the instructions below, or fill out the form at [www.tennsco.com/partsorder.html](http://www.tennsco.com/partsorder.html).**

**TO OBTAIN PROPER REPLACEMENT PARTS, PLEASE PROVIDE THE FOLLOWING INFORMATION:**

- Model Number
- Description of part(s) needed and part number(s) as shown in Parts List (above)
- Color (i.e. Medium Grey, Sand, etc.)
- Was item missing, or was it damaged?
- Purchase Date
- Your company name
- Contact person's name
- Company the product was purchased from

Tennsco Corp., P.O. Box 1888, Dickson, TN 37056-1888 E-mail address: [info@tennsco.com](mailto:info@tennsco.com)

Customer Service: (866) 446-8686 Fax: (866) 445-7260

If requesting parts by telephone, ask for customer service and have as much of the above information ready as possible.

**LIMITED WARRANTY**

Tennsco warrants goods purchased hereunder to be free of defects in materials and workmanship for a period of one (1) year from the date of shipment, hereunder. This warranty shall not apply in the event goods are damaged as a result of misuse, abuse, neglect, accident, improper application, modification or repair by persons not authorized by Seller, where goods are damaged during shipment, or where the date stamps on the goods have been defaced, modified or removed. UNLESS CONSIDERED UNENFORCEABLE OR UNLAWFUL UNDER APPLICABLE LAW:

- a. ALL IMPLIED WARRANTIES, INCLUDING BUT NOT LIMITED TO WARRANTIES OR MERCHANTABILITY AND FITNESS FOR A PARTICULAR PURPOSE ARE HEREBY EXCLUDED:
- b. BUYERS REMEDY, IF ANY, FOR ANY DEFECTIVE GOODS SHALL BE LIMITED TO A REFUND BY SELLER OR REPLACEMENT OF THE GOODS AT SELLER'S OPTION, AND SHALL IN NO EVENT INCLUDE DAMAGES OF ANY KIND, WHETHER INCIDENTAL, CONSEQUENTIAL OR OTHERWISE.

NO GOODS ACCEPTED FOR RETURN WITHOUT PRIOR APPROVAL. Seller shall have the right to inspect any goods claimed to be defective at Buyers place of business or require Buyer to return the goods to Seller for inspection on Seller's premises. Transportation charges covering returned goods will be borne by Seller only if such goods are proven to be defective, are covered by this warranty and are returned within the warranty period stated above.

TENNSCO Corp., P.O. BOX 1888, DICKSON, TN 37056-1888

(615) 446-8000 or (866) 446-8686 (toll free)

Website: [www.tennsco.com](http://www.tennsco.com) E-mail: [Info@tennsco.com](mailto:Info@tennsco.com)

**STEP 1)** Locate the Leveling Screws (#1) (a quantity of 8 will be required for the 36" units, and 10 for the 48"). Thread them into the Track Assembly (#2) through the weld nuts with the socket facing up. Adjust all screws into their upper most position. Continue this procedure until each Track Assembly in the system is complete.

**STEP 2)** Locate the Floor Protecting Channels (#3) on the floor with the "U" facing up; two (2) will be needed for each Track Assembly. Approximate the position for the Floor Protector Channels (#3) and lay them in place. Next lay the Track Assemblies on top of the channels. The leveling screws should be directly on top of the channels.

**STEP 3)** Locate the Roll Pin (#4) and drive it into the hole drilled at the end of each track. This is designed to fit very tightly and will require a ball peen hammer. The opening will only permit the Roll Pin to be driven in partially; the remaining portion of the Roll Pin will fit into the opening in the next Track Assembly. Position the next Track Assembly in place; make sure you have a tight fit to insure smooth operation.

**STEP 4)** Once you have joined the Track Assemblies together, locate the Track Splice Channel (#5). Install the Track Splice Channel over the flange at the rear of the Track Assembly and secure using a 10 - 32 x 1 3/4 hex head screw (#6), external tooth lock washer, and 1/4 x 20 hex nut (#7). Tighten firmly making sure that each track is secure to the next.

**STEP 5)** Install the Rubber Bumpers (#8) at the end of each Track Assembly run, using two- (2) 1/4 x 1/2 self-tapping screws. If these are not installed the carriage will roll off the end of the track.

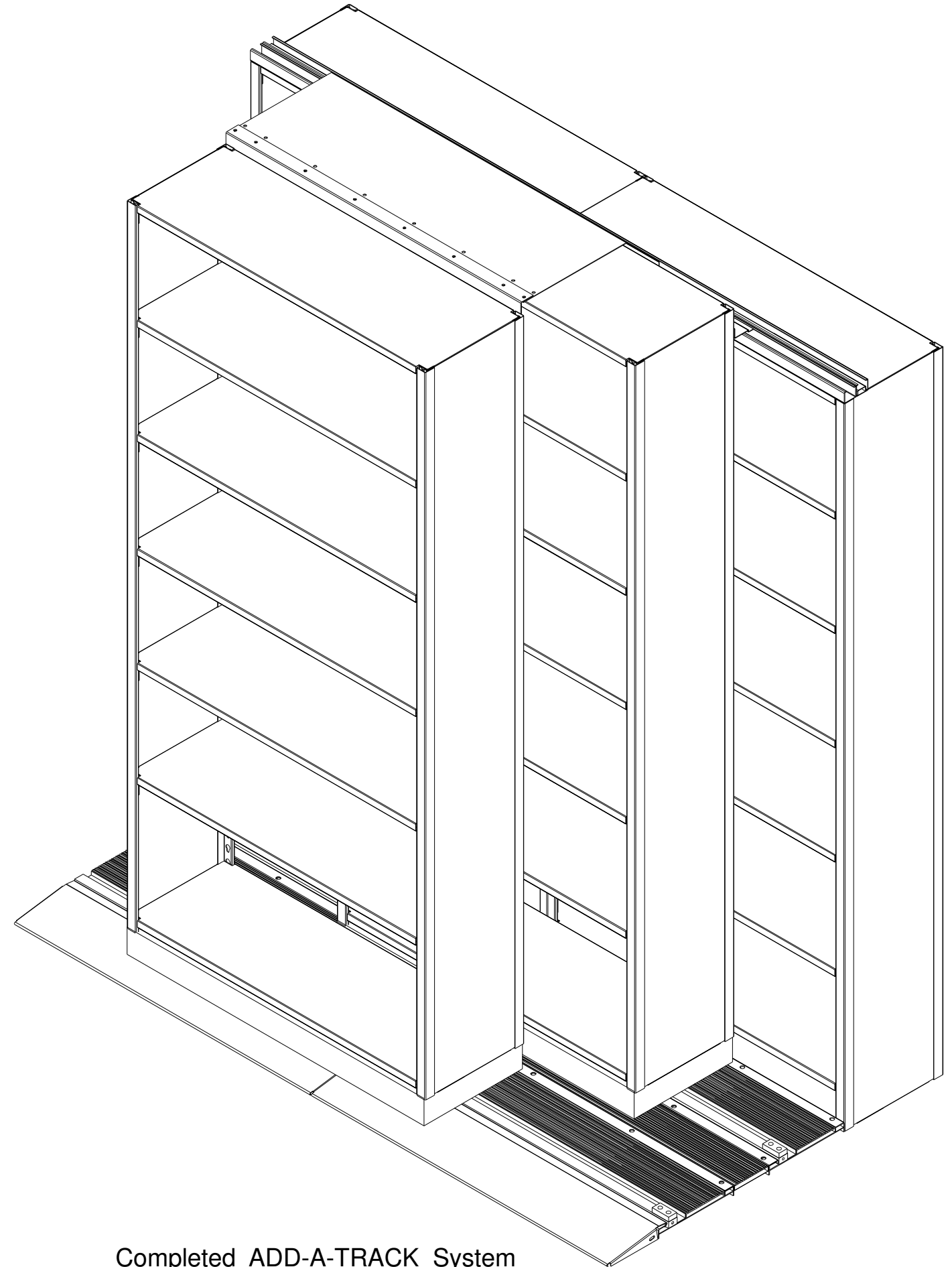
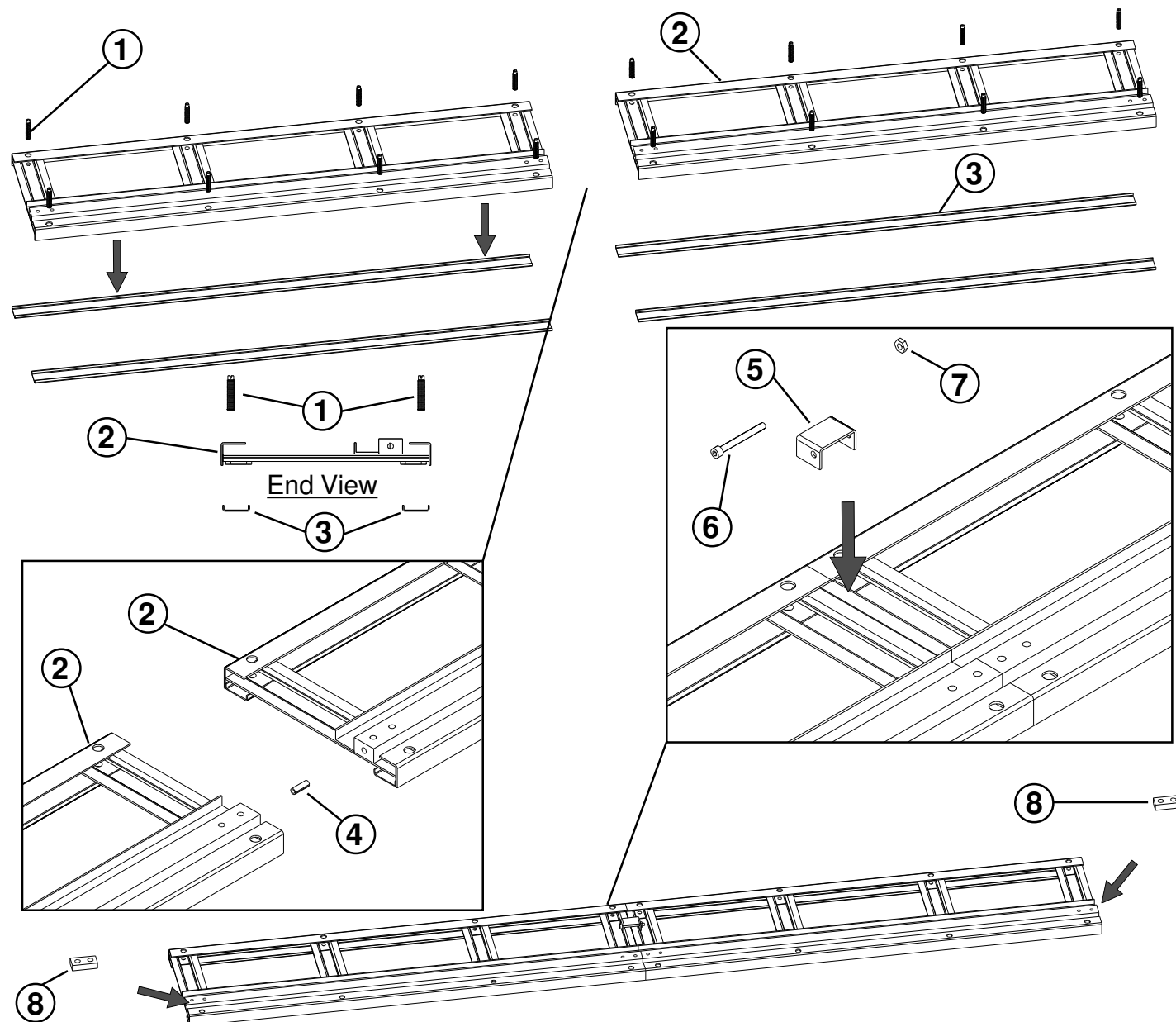

Completed ADD-A-TRACK System

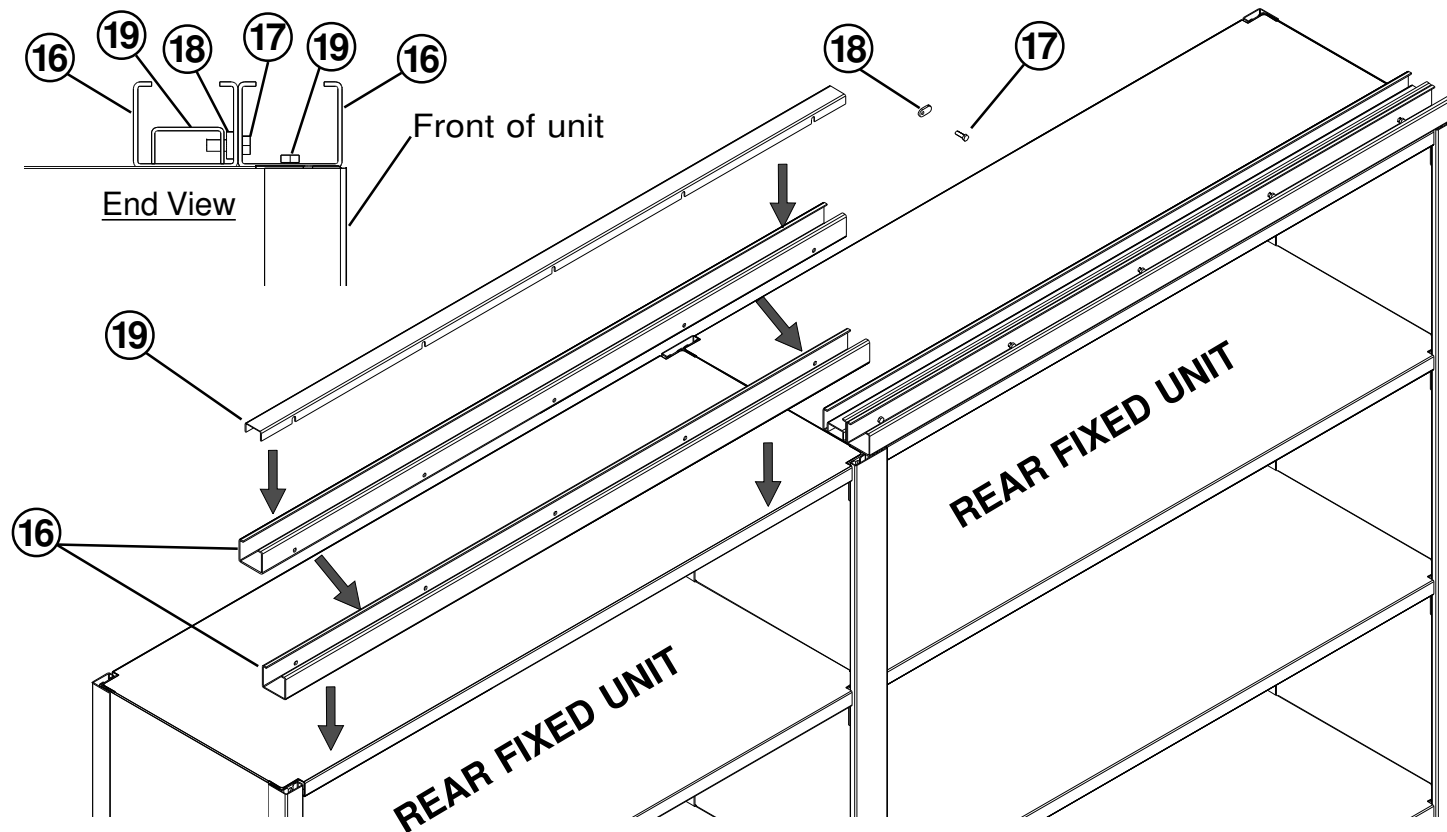

**STEP 10a)** Lay one Top Track (#16) on top of the unit and drill two holes through the shelf and the shelf support and bolt the Top Track to the shelf & support. **10b)** Attach the second Top Track as shown to the first Top Track using five 8-32 x 1/2 Hex Head Machine Screw (#17), lock washers and plates nuts (#18). **10c)** Insert the Roller Guide Channel (#19) as an inverted "U" so slots in Roller Guide slide over the five screws into the second (rear) Top Track as shown. Tighten all hardware.

**STEP 11)** Next lift one of the L&T units (#20) and mount it to the top of the Mobile Carriage (#21) using four (4) 1/4 - 20 x 1 bolts (#22), and 1/4 - 20 hex head nuts (#23). The uprights of the L&T unit have a flange on the bottom of the upright with two holes in it to attach the upright to the Carriage. This can be done with the unit complete but you will need to lift the lower shelf to gain access to the flanges and holes in it. You may also attach the unit to the carriage by inserting a self tapping screw through the holes on a single-riquet heavy duty support (not shown) on the bottom level of the unit and screwing it into the carriage frame.

**STEP 12)** Repeat step 11 for each unit to be mounted on a Mobile Carriage.

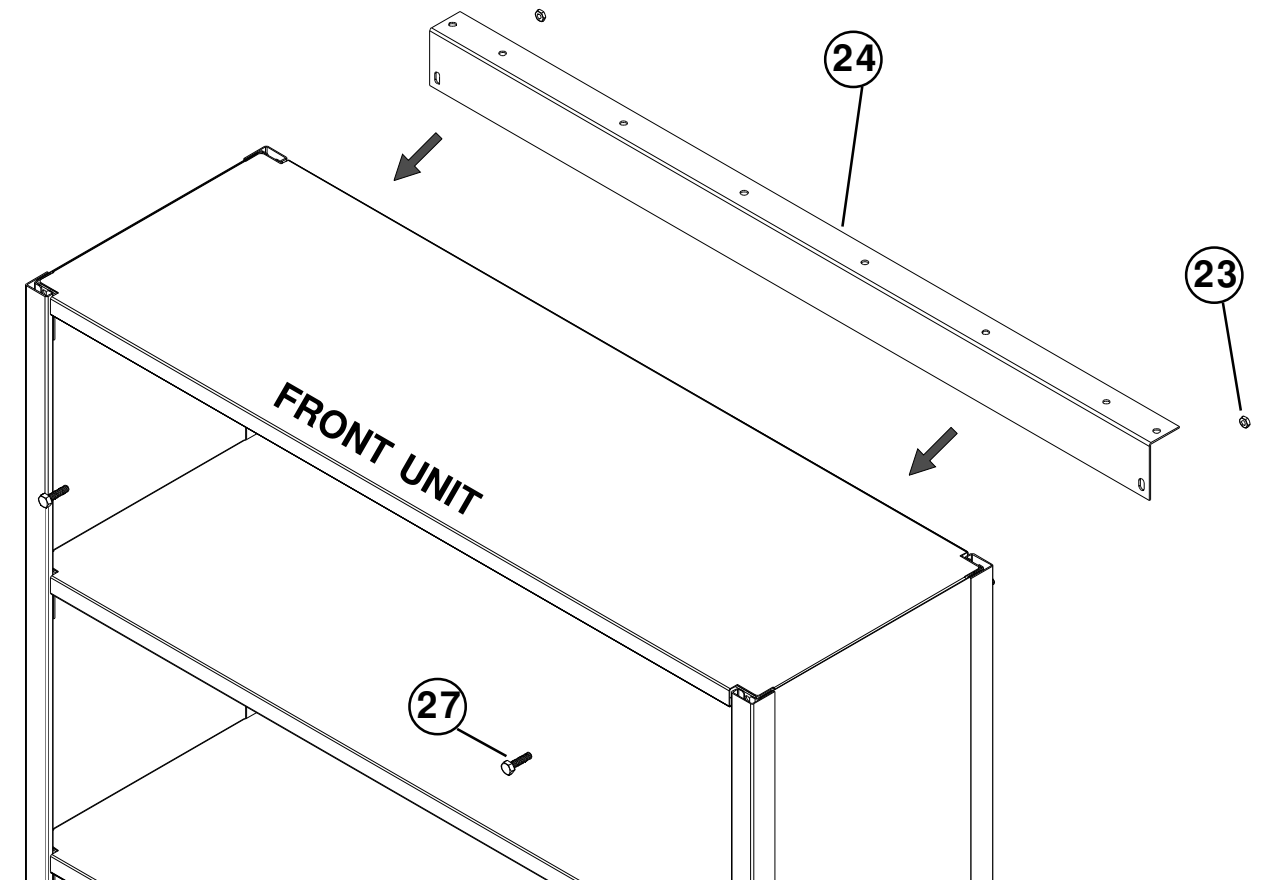
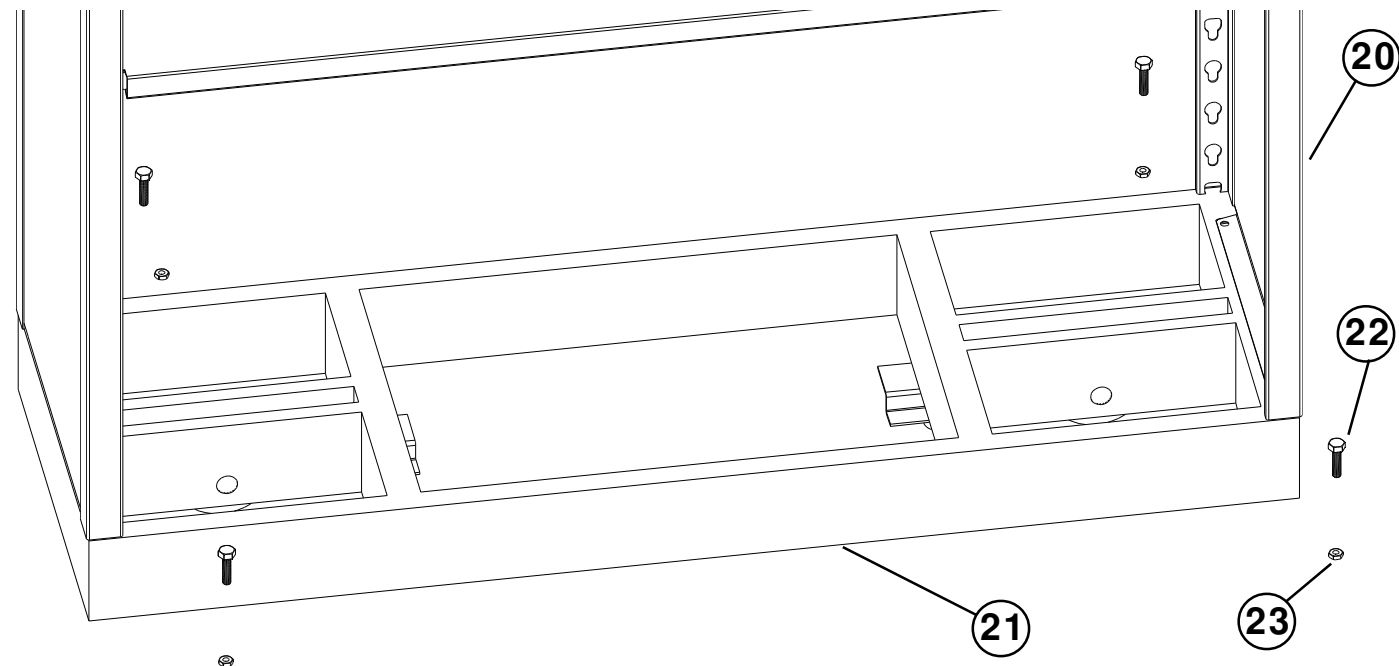

**STEP 13)** Mount the Stabilizer Support Angle (#24) to the rear of the front L&T unit, use the support angle to locate the two holes that will need to be drilled through the rear upright. These holes will need to be 1/4 diameter and located approximately 1 1/2 from the top. Attach using two- (2) 1/4-x-20 x 1 1/2 bolts (#22) and 1/4 - 20 nuts (#23).

**STEP 14)** Lift the unit with carriage onto the solid steel rod, which is what the steel roller of the carriage will ride on. Have someone hold the units plumb and slide the Stabilizer Cover Roller Bracket Assembly (#26) into the second Top Track Assembly. Bolt the Stabilizer Cover Roller Bracket Assembly (#26) to the Stabilizer Support Angle (#24) on the front unit using five (5) 1/4 - 20 x 1/2 bolts (#27) and 1/4 x 20 nuts (#23). The Stabilizer Cover Roller Bracket Assembly has two sets of holes that are used to attach to the Stabilizer Support Angle. Use the set of holes that will allow the units align vertically with the rear units.

**STEP 15)** Next slide the Stabilizer Roller Bracket Assembly (#25) into the first Top Track. Then attach the Stabilizer Roller Bracket Assembly (#25) to the rear of the middle unit as shown. You will need to hold the Stabilizer Roller Bracket Assembly (#25) level and locate on the upright where the two holes will need to be drilled to attach the bracket (#25). Now attach the bracket (#25) to the unit and see if the unit rolls freely on the steel track. The steel wheel of the carriage will roll on the square steel bar in the floor assembly. Do not have the carriage rolling on any surface except the steel bar. Some adjustment may be needed to the brackets for a smooth free operation.

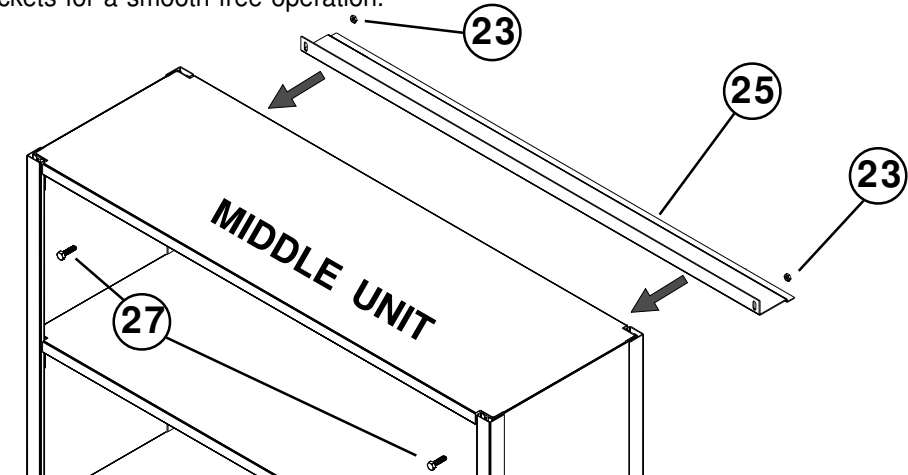

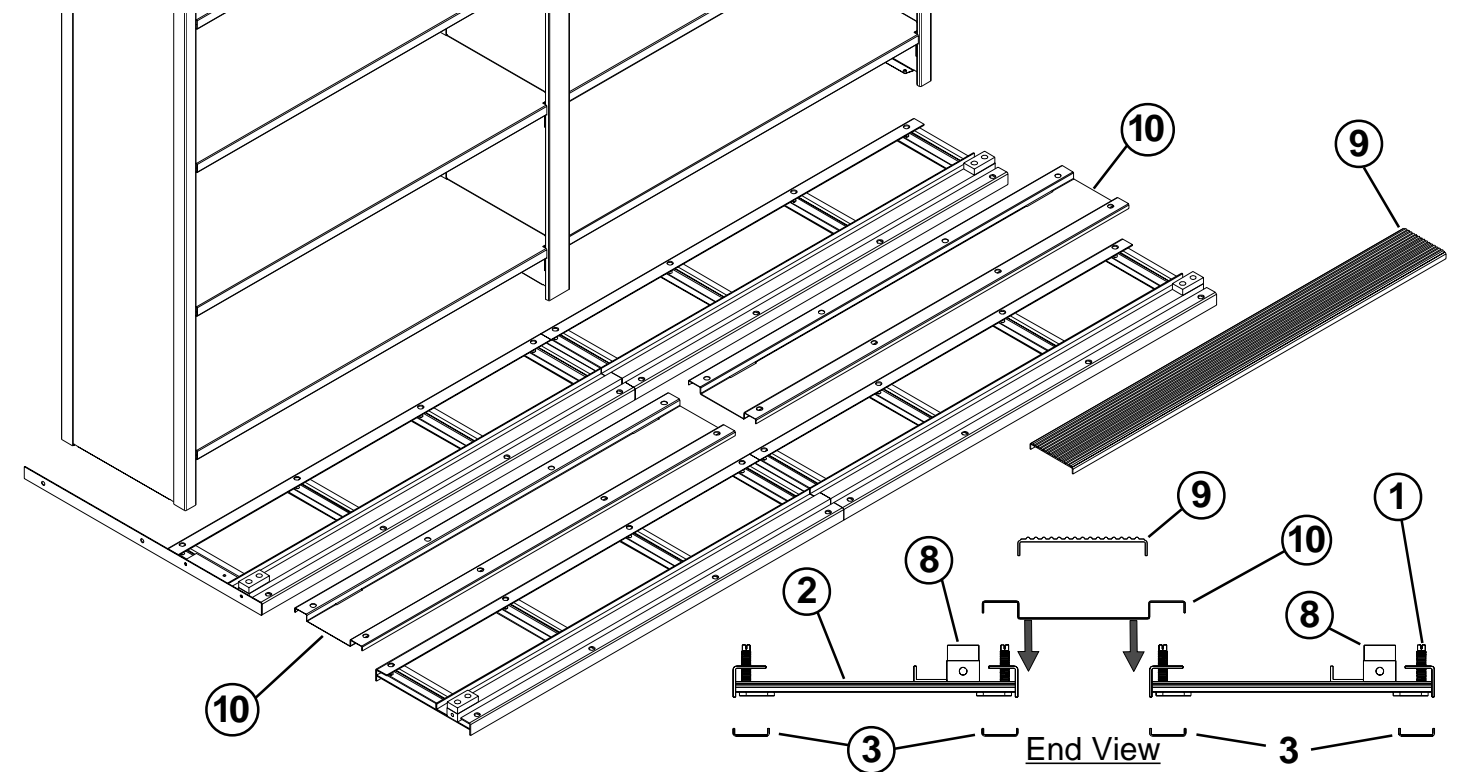
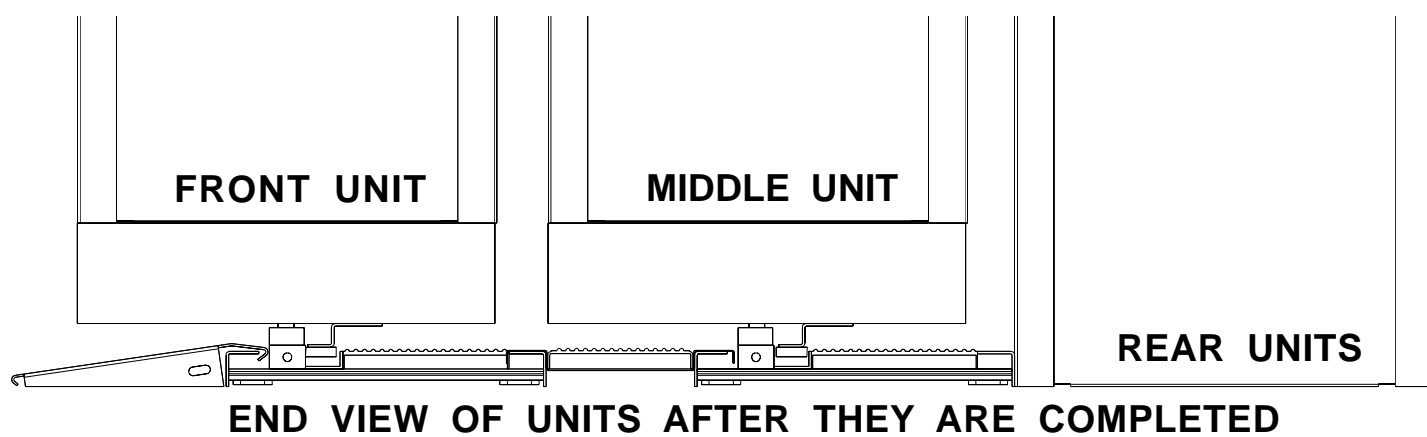
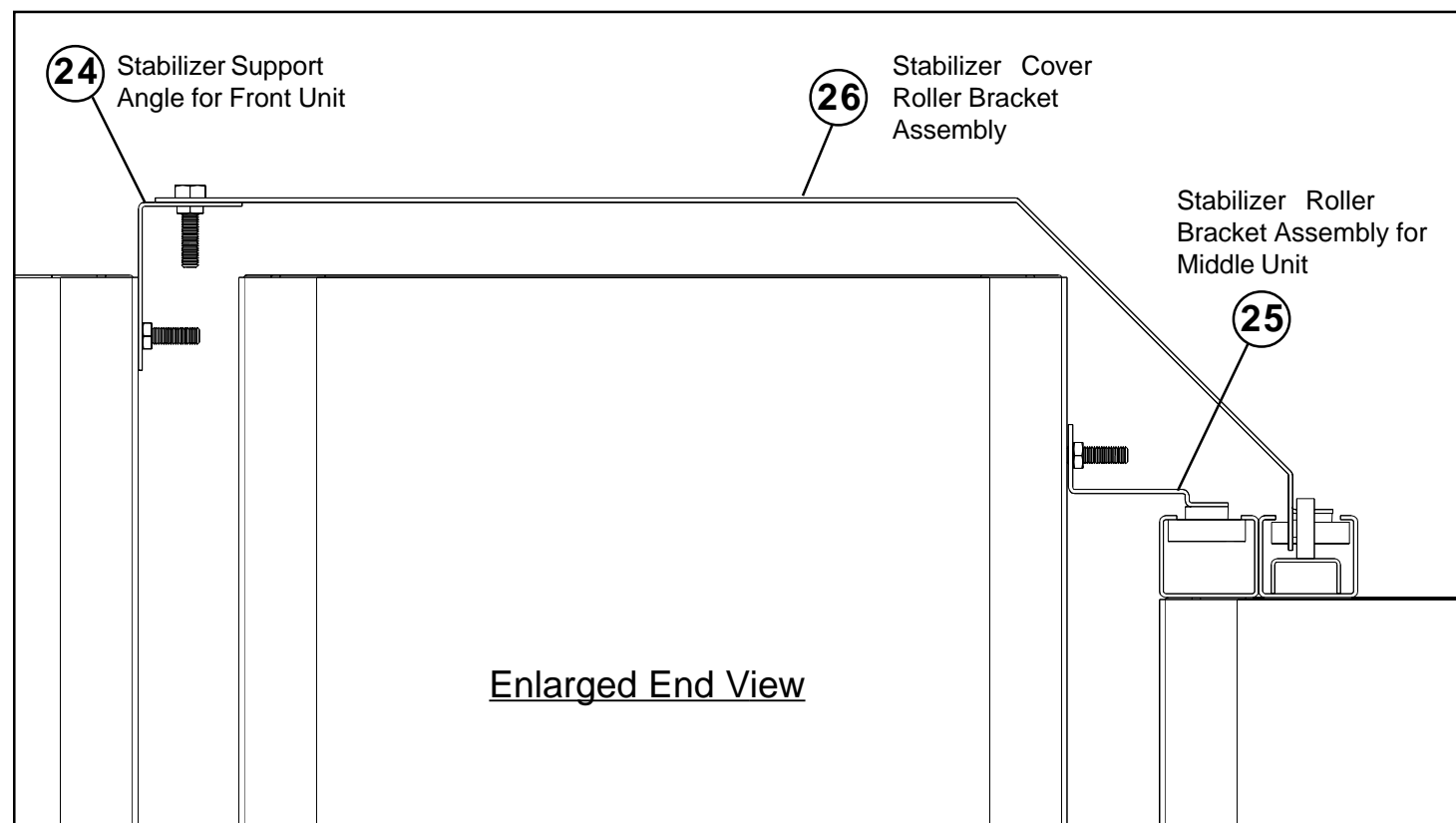
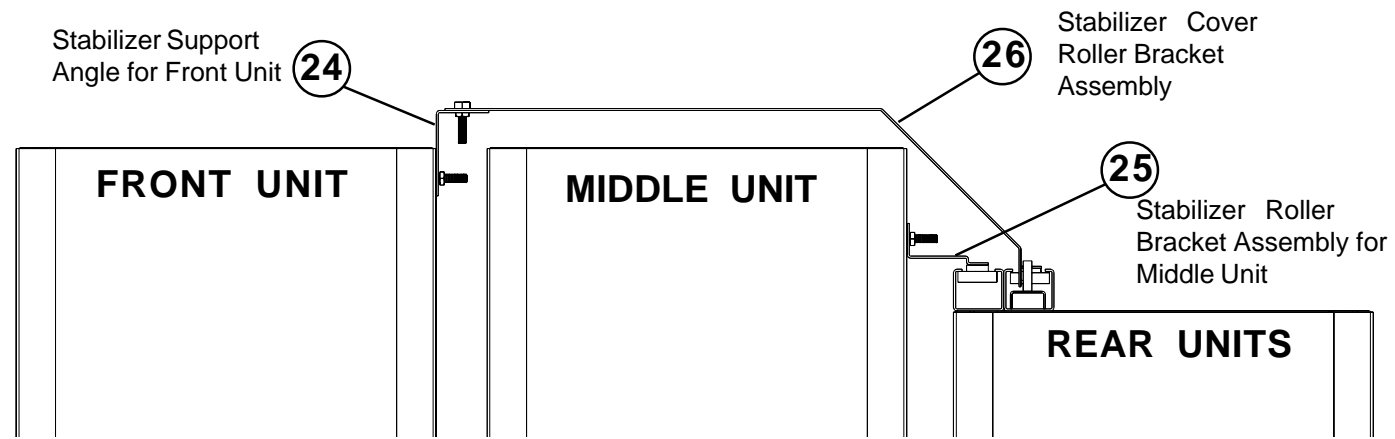

**STEP 6)** Place the Deck Covers (#9) into the open portion of the Track Assembly. They are approximately 6" x 36" or 48" and have a ribbed safety vinyl laminated to the surface.

**STEP 7)** Place the Track Assembly (#2) next to the L&T unit that has been pre-installed. Place the Track Spreader Panel (#10) over the Track Assembly sections as shown. Insert the Deck Covers (#11) into the Track Spreader Panel.

**STEP 8)** Slide the Ramp Plates (#12) onto the front of the Track Assemblies.

**STEP 9)** At both ends of the floor assembly, attach one end of the Track End Plate (#13) to the End Plate Angle (#14) using two (2) machine screws (#15). Then attach this assembly to the end of the L&T unit section. This will insure that this floor assembly does not move.

