

POLICY AND SERVICES

PRICING: All prices are knocked down, F.O.B. Tennsco Corp's Facility in Dickson, Tennessee. All orders are subject to final acceptance at the Home Office, Dickson, Tennessee. Prices are subject to change without notice. Tennsco's prices do not include sales, use, excise or similar taxes. Consequently, in addition to the prices specified herein, the amount of any present or future sales, use, excise or similar tax applicable to the manufacture, sale, purchase or use of the goods sold hereunder shall be paid by buyer. In lieu thereof, Buyer shall provide Seller with a tax exemption certificate acceptable to the applicable taxing authorities.

TERMS OF PAYMENT: Terms are Net 30 Days from date of shipment. A service charge of 1 ½% per month will be charged for overdue invoices.

MINIMUM ORDERS: Minimum order is \$15.00.

FREIGHT CHARGES: All shipments will be made freight collect unless otherwise specified. If freight is prepaid, it will be added to the invoice or billed separately, depending on arrangements. On shipments by parcel post, the postage will be added to the invoice. All routing will be done solely by the Home Office.

WEIGHT: Weights shown are approximate.

CLAIMS: Claims for shortages must be made in writing to the Home Office within 15 days from receipt of shipment. Claims for damaged or lost material must be filed with the carrier.

Caution: When you give delivering carrier a clear receipt for a shipment in which there is damaged merchandise or a shortage, the carrier is relieved of further responsibility. Claims for damage or shortage must be filed by you with the delivering carrier. Tennsco will not accept return of merchandise damaged in transit. Your claim is with the delivering carrier.

PARTIAL SHIPMENTS: Tennsco reserves the right to make delivery in installments unless otherwise expressly stated herein. All such installments shall be separately invoiced and paid for when due, without regard to subsequent deliveries. Delay in delivery of all installments shall not relieve Buyer of its obligations to accept remaining deliveries.

SET UP: Set up of certain units will be made at the factory when specified. Unless specifically priced otherwise, charge will be 15% of list price (not subject to discount). Some products are packaged KD only.

CANCELLATIONS & RETURNS: Orders for "Non Stock" items are not subject to change or cancellation. No return merchandise will be accepted without written consent of the General Office, Dickson, Tennessee. All returned shipments are subject to a handling charge of 25% plus all transportation charges incurred by Tennsco unless Tennsco is at fault. Cancelled orders, prior to shipment, are subject to a 15% charge of the goods covered by the cancellation order.

LIMITED WARRANTY

Tennsco warrants goods purchased hereunder to be free of defects in materials and workmanship for a period of one (1) year from the date of shipment, hereunder. Products with the Logic Coat finish are warranted against rust for five (5) years from the date of shipment. This warranty shall not apply in the event goods are damaged as a result of misuse, abuse, neglect, accident, improper application, modification or repair by persons not authorized by Seller, where goods are damaged during shipment, or where the date stamps on the goods have been defaced, modified or removed. UNLESS CONSIDERED UNENFORCEABLE OR UNLAWFUL UNDER APPLICABLE LAW:

- ALL IMPLIED WARRANTIES, INCLUDING BUT NOT LIMITED TO WARRANTIES OR MERCHANTABILITY AND FITNESS FOR A PARTICULAR PURPOSE ARE HEREBY EXCLUDED;
- BUYERS REMEDY, IF ANY, FOR ANY DEFECTIVE GOODS SHALL BE LIMITED TO A REFUND BY SELLER OR REPLACEMENT OF THE GOODS AT SELLER'S OPTION, AND SHALL IN NO EVENT INCLUDE DAMAGES OF ANY KIND, WHETHER INCIDENTAL, CONSEQUENTIAL OR OTHERWISE.

NO GOODS ACCEPTED FOR RETURN WITHOUT PRIOR APPROVAL. Seller shall have the right to inspect any goods claimed to be defective at Buyers place of business or require Buyer to return the goods to Seller for inspection on Seller's premises. Transportation charges covering returned goods will be borne by Seller only if such goods are proven to be defective, are covered by this warranty and are returned within the warranty period stated above.

MAILING ADDRESS:
Tennsco Corp.
P.O. Box 1888
Dickson, TN 37056-1888

SHIPPING ADDRESS:
Tennsco Corp.
201 Tennsco Drive
Dickson, TN 37055

tennsco
Systems for Success

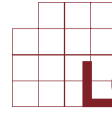

LOGIC SYSTEMS®

SHELVING

PRICE LIST

MAILING ADDRESS:
Tennsco Corp.
P.O. Box 1888
Dickson, TN 37056-1888

SHIPPING ADDRESS:
Tennsco Corp.
201 Tennsco Drive
Dickson, TN 37055

CORPORATE OFFICE: (615) 446-8000
(800) 251-8184
(800) 722-0134 (Fax)

CUSTOMER SERVICE: (866) 446-8686
(866) 864-4796

EFFECTIVE JUNE 1, 2011

This price list supersedes all previous price lists.
Prices subject to change without notice.

CONTENTS

PAGE 2: Logic Clips, Clamps and Posts
PAGE 3: Shelves
PAGE 4: 75" Wire Shelving Units
PAGE 5: 75" and 87" Solid Shelving Units
PAGE 6: Carts & Accessories
PAGE 7: Accessories
**PAGE 8: Three Sided Channel Brace;
Wall Brackets**

AVAILABLE FINISHES: Powder Epoxy, Logic Coat,
Nickel Chrome

EPOXY COLORS: Arctic White, Black, Pearl Grey

TENNSCO QUICK-SHIP PROGRAM



NEED AN ORDER FAST? Look for this logo throughout the book.

Based on past sales history, Tennsco inventories many of its most popular items, usually available for shipment in three business days. Quick Ship inventory is available in limited quantities and selected colors. For larger orders, please contact customer service for availability.

◆ Items marked with a red diamond are available for quick ship in Arctic White and Pearl Grey, unless otherwise specified.

NSF Listed

LOGIC® CLIPS AND CLAMPS

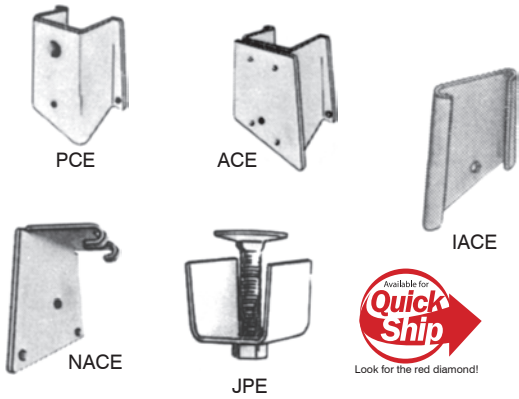

◆ QUICKSHIP COLORS: Epoxy: Arctic White, Pearl Grey; Logic Coat: Logic Coat only

DESCRIPTION	EPOXY		CHROME		LOGIC COAT	
	CAT. NO.	PRICE	CAT. NO.	PRICE	CAT. NO.	PRICE
POST CLIP	PCE ◆	.49	PCR	1.20	PCC ◆	.63
ADD ON CLIP	ACE ◆	1.80	ACR	3.00	ACC ◆	2.20
90° ANGLE CLIP	NACE	1.90	NACR	2.70	NACC	2.00
90° JOINING CLAMP (For Solid Shelf)	JPE	6.20				
INTERMEDIATE ADD-ON CLIP (For closing off an add-on clip when shelf is not used on adjacent level)	IACE	.32	IACR	1.10	IACC	.40

LOGIC® POSTS

◆ QUICKSHIP COLORS: Arctic White and Pearl Grey

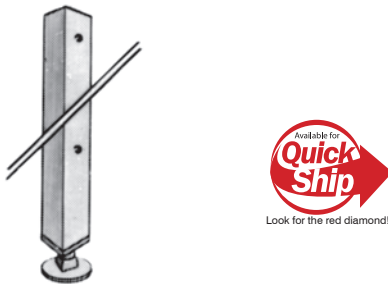

Special length posts are priced as next higher length plus a cutting charge of \$2.00 (list) per post.

H	EPOXY		CHROME		LOGIC COAT		WT.
	CAT. NO.	PRICE	CAT. NO.	PRICE	CAT. NO.	PRICE	
STANDARD POST							
14	PE-14	19.30	PR-14	25.00	PC-14	23.00	1.2
42	PE-42	22.00	PR-42	34.00	PC-42	30.00	3.1
57	PE-57	23.00	PR-57	35.00	PC-57	34.00	4.4
63	PE-63	25.00	PR-63	37.00	PC-63	40.00	4.8
75	PE-75 ◆	25.00	PR-75	38.00	PC-75	41.00	5.5
87	PE-87	30.00	PR-87	43.00	PC-87	47.00	6.5
NO-GLIDE POST (for use with casters)							
14	PE-14NG	19.30	PR-14NG	25.00	PC-14NG	23.00	1.2
42	PE-42NG	22.00	PR-42NG	34.00	PC-42NG	30.00	3.1
57	PE-57NG	23.00	PR-57NG	35.00	PC-57NG	34.00	4.4
63	PE-63NG	25.00	PR-63NG	37.00	PC-63NG	40.00	4.8
75	PE-75NG	25.00	PR-75NG	38.00	PC-75NG	41.00	5.5
87	PE-87NG	30.00	PR-87NG	43.00	PC-87NG	47.00	6.5

STARTER / ADD-ON CONFIGURATIONS

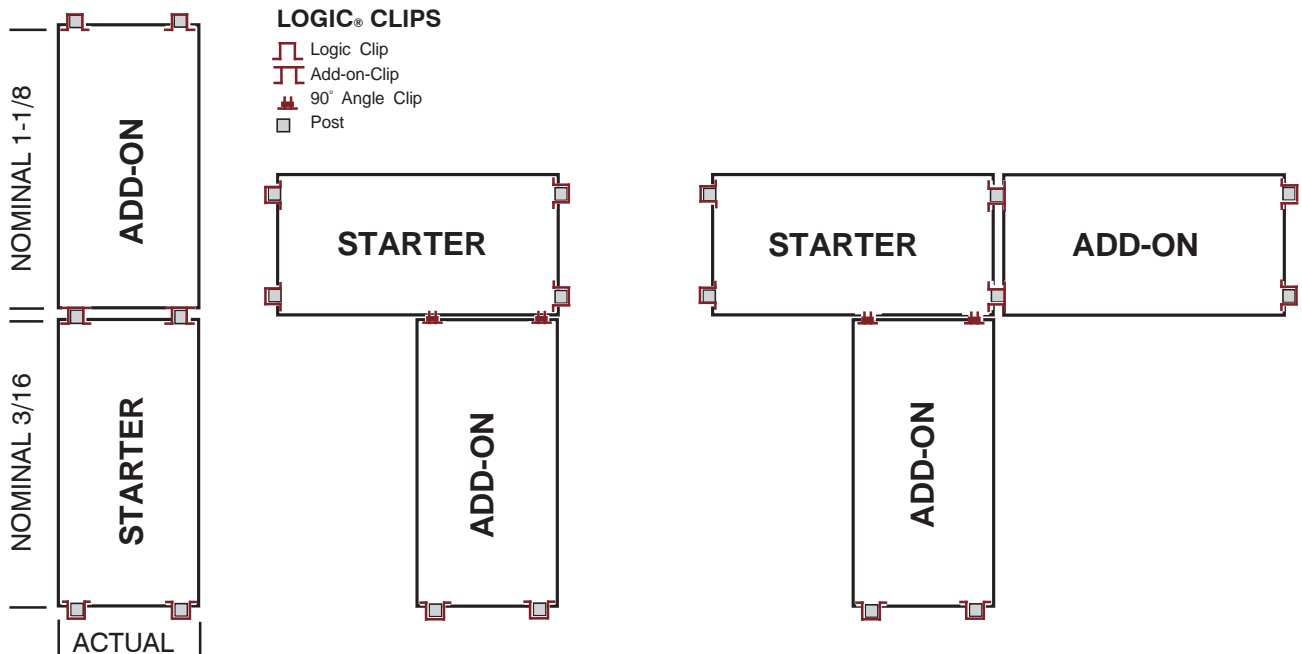

SHELVES

WIRE SHELVES

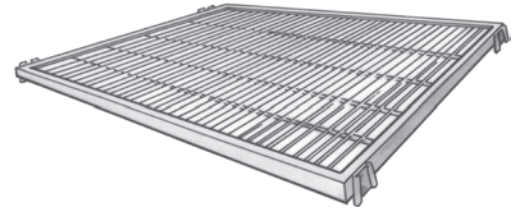

◆ QUICKSHIP COLORS: Arctic White and Pearl Grey

W	D	EPOXY		CHROME		LOGIC COAT		WT.
		CAT. NO.	PRICE	CAT. NO.	PRICE	CAT. NO.	PRICE	
24	18	LE-2418	85.00	LR-2418	165.00	LC-2418	99.00	7.3
24	24	LE-2424	104.00	LR-2424	188.00	LC-2424	123.00	9.0
30	18	LE-3018	81.00	LR-3018	161.00	LC-3018	101.00	8.7
30	24	LE-3024	96.00	LR-3024	180.00	LC-3024	125.00	10.6
36	18	LE-3618 ◆	69.00	LR-3618	148.00	LC-3618	88.00	10.2
36	24	LE-3624 ◆	79.00	LR-3624	164.00	LC-3624	98.00	12.3
42	18	LE-4218	87.00	LR-4218	163.00	LC-4218	107.00	11.5
42	24	LE-4224	88.00	LR-4224	170.00	LC-4224	117.00	14.0
48	18	LE-4818 ◆	81.00	LR-4818	158.00	LC-4818	100.00	13.0
48	24	LE-4824	91.00	LR-4824	176.00	LC-4824	120.00	15.7
60	18	LE-6018	100.00	LR-6018	207.00	LC-6018	129.00	21.0
60	24	LE-6024 ◆	110.00	LR-6024	216.00	LC-6024	143.00	25.0
72	18	LE-7218	124.00	LR-7218	238.00	LC-7218	153.00	26.0
72	24	LE-7224 ◆	134.00	LR-7224	243.00	LC-7224	167.00	30.0



Four Logic Clips (not included) are required to attach shelves to posts. Order Logic Clips at top of page 2.
Actual shelf widths are 2 1/2" less than nominal sizes shown.

SOLID SHELVES

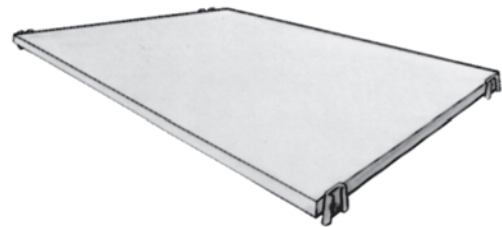

W	D	EPOXY		WT.
		CAT. NO.	PRICE	
24	18	LES-2418	71.00	9.2
24	24	LES-2424	75.00	11.7
30	18	LES-3018	75.00	11.0
30	24	LES-3024	88.00	14.5
36	18	LES-3618	81.00	13.5
36	24	LES-3624	94.00	17.2
42	18	LES-4218	85.00	15.6
42	24	LES-4224	95.00	19.9
48	18	LES-4818	90.00	17.8
48	24	LES-4824	110.00	23.0
60	18	LES-6018	109.00	22.0
60	24	LES-6024	112.00	28.0
72	18	LES-7218	135.00	26.0
72	24	LES-7224	156.00	34.0

Four Logic Clips (not included) are required to attach shelves to posts. Order Logic Clips at top of page 2.
Actual shelf widths are 2 1/2" less than nominal sizes shown.

WIRE SHELVING UNITS

4 Shelves, 75" High

STARTER UNITS



Units include four posts, four wire shelves, Logic Clips and leveling feet.

◆ QUICKSHIP COLORS: Arctic White and Pearl Grey

W	D	EPOXY		CHROME		LOGIC COAT		WT.
		CAT. NO.	PRICE	CAT. NO.	PRICE	CAT. NO.	PRICE	
36	18	E-361875-4◆	384.00	R-361875-4	763.00	C-361875-4	526.00	64.0
36	24	E-362475-4◆	424.00	R-362475-4	827.00	C-362475-4	566.00	73.0
42	18	E-421875-4	456.00	R-421875-4	823.00	C-421875-4	602.00	70.0
42	24	E-422475-4	460.00	R-422475-4	851.00	C-422475-4	642.00	80.0
48	18	E-481875-4◆	432.00	R-481875-4	803.00	C-481875-4	574.00	76.0
48	24	E-482475-4	472.00	R-482475-4	875.00	C-482475-4	654.00	86.0
60	18	E-601875-4	508.00	R-601875-4	999.00	C-601875-4	690.00	108.0
60	24	E-602475-4◆	548.00	R-602475-4	1035.00	C-602475-4	746.00	124.0
72	18	E-721875-4	604.00	R-721875-4	1123.00	C-721875-4	786.00	128.0
72	24	E-722475-4◆	644.00	R-722475-4	1143.00	C-722475-4	842.00	144.0

ADD-ON UNITS

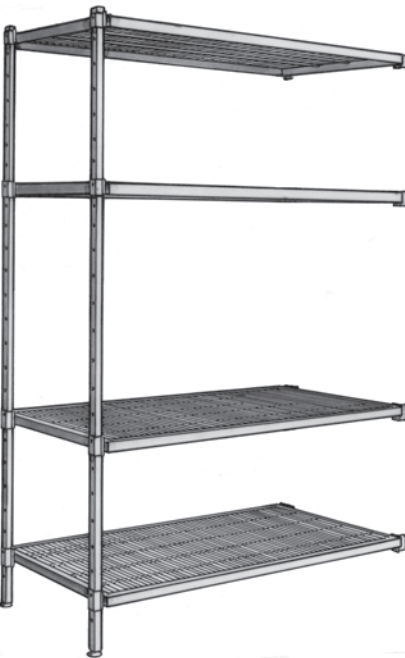

Units include two posts, four wire shelves, Logic Clips and leveling feet.

◆ QUICKSHIP COLORS: Arctic White and Pearl Grey

W	D	EPOXY		CHROME		LOGIC COAT		WT.
		CAT. NO.	PRICE	CAT. NO.	PRICE	CAT. NO.	PRICE	
36	18	E-361875-4A◆	340.00	R-361875-4A	692.00	C-361875-4A	452.00	53.0
36	24	E-362475-4A◆	380.00	R-362475-4A	756.00	C-362475-4A	492.00	62.0
42	18	E-421875-4A	412.00	R-421875-4A	752.00	C-421875-4A	528.00	59.0
42	24	E-422475-4A	416.00	R-422475-4A	780.00	C-422475-4A	568.00	69.0
48	18	E-481875-4A◆	388.00	R-481875-4A	732.00	C-481875-4A	550.00	65.0
48	24	E-482475-4A	428.00	R-482475-4A	804.00	C-482475-4A	580.00	75.0
60	18	E-601875-4A	464.00	R-601875-4A	928.00	C-601875-4A	616.00	97.0
60	24	E-602475-4A◆	504.00	R-602475-4A	964.00	C-602475-4A	672.00	113.0
72	18	E-721875-4A	560.00	R-721875-4A	1052.00	C-721875-4A	712.00	117.0
72	24	E-722475-4A◆	600.00	R-722475-4A	1072.00	C-722475-4A	768.00	133.0

SOLID SHELVING UNITS



4 SHELVES, 75" HIGH



W	D	STARTER UNITS EPOXY			ADD ON UNITS EPOXY		
		CAT. NO.	PRICE	WT.	CAT. NO.	PRICE	WT.
36	18	ES-361875-4	432.00	81.0	ES-361875-4A	438.00	80.0
36	24	ES-362475-4	484.00	96.0	ES-362475-4A	440.00	83.0
42	18	ES-421875-4	448.00	89.0	ES-421875-4A	454.00	88.0
42	24	ES-422475-4	488.00	106.0	ES-422475-4A	444.00	93.0
48	18	ES-481875-4	468.00	98.0	ES-481875-4A	424.00	85.0
48	24	ES-482475-4	548.00	119.0	ES-482475-4A	504.00	106.0
60	18	ES-601875-4	544.00	115.0	ES-601875-4A	500.00	102.0
60	24	ES-602475-4	556.00	139.0	ES-602475-4A	512.00	126.0

Starter units include four posts, four solid shelves, Logic Clips and leveling feet; Add-on units include two posts, four solid shelves, Logic Clips and leveling feet.

6 SHELVES, 87" HIGH



W	D	STARTER UNITS EPOXY			ADD ON UNITS EPOXY		
		CAT. NO.	PRICE	WT.	CAT. NO.	PRICE	WT.
36	18	ES-361887-6	618.00	110.0	ES-361887-6A	568.00	96.0
36	24	ES-362487-6	696.00	132.0	ES-362487-6A	646.00	118.0
42	18	ES-421887-6	642.00	123.0	ES-421887-6A	592.00	109.0
42	24	ES-422487-6	702.00	149.0	ES-422487-6A	652.00	135.0
48	18	ES-481887-6	672.00	136.0	ES-481887-6A	622.00	122.0
48	24	ES-482487-6	792.00	167.0	ES-482487-6A	742.00	153.0
60	18	ES-601887-6	786.00	161.0	ES-601887-6A	736.00	147.0
60	24	ES-602487-6	804.00	197.0	ES-602487-6A	754.00	183.0

Starter units include four posts, six solid shelves, Logic Clips and leveling feet; Add-on units include two posts, six solid shelves, Logic Clips and leveling feet.

WIRE SHELF CARTS



Units include four posts, four wire shelves, Logic Clips, four donut bumpers and two pair of swivel casters.

W	D	EPOXY		CHROME		LOGIC COAT		WT.
		CAT. NO.	PRICE	CAT. NO.	PRICE	CAT. NO.	PRICE	
4 Shelves, 57" Post Height								
36	18	ME-361862-4	456.00	MR-361862-4	831.00	MC-361862-4	578.00	70.0
36	24	ME-362462-4	496.00	MR-362462-4	895.00	MC-362462-4	618.00	78.0
42	18	ME-421862-4	528.00	MR-421862-4	891.00	MC-421862-4	654.00	75.0
42	24	ME-422462-4	532.00	MR-422462-4	919.00	MC-422462-4	694.00	85.0
48	18	ME-481862-4	504.00	MR-481862-4	871.00	MC-481862-4	626.00	81.0
48	24	ME-482462-4	544.00	MR-482462-4	943.00	MC-482462-4	706.00	92.0
60	18	ME-601862-4	580.00	MR-601862-4	1067.00	MC-601862-4	742.00	113.0
60	24	ME-602462-4	620.00	MR-602462-4	1103.00	MC-602462-4	822.00	129.0
4 Shelves, 62" Post Height								
36	18	ME-361868-4	464.00	MR-361868-4	839.00	MC-361868-4	602.00	72.0
36	24	ME-362468-4	504.00	MR-362468-4	903.00	MC-362468-4	642.00	80.0
42	18	ME-421868-4	536.00	MR-421868-4	899.00	MC-421868-4	678.00	77.0
42	24	ME-422468-4	540.00	MR-422468-4	927.00	MC-422468-4	708.00	87.0
48	18	ME-481868-4	512.00	MR-481868-4	879.00	MC-481868-4	650.00	83.0
48	24	ME-482468-4	552.00	MR-482468-4	951.00	MC-482468-4	730.00	94.0
60	18	ME-601868-4	588.00	MR-601868-4	1075.00	MC-601868-4	766.00	115.0
60	24	ME-602468-4	628.00	MR-602468-4	1111.00	MC-602468-4	822.00	131.0

WIRE SHELF HAND CARTS



Units include two one-piece handles, two or three wire shelves, Logic Clips, four donut bumpers, and two pair of swivel casters.



◆ QUICKSHIP COLORS: Arctic White and Pearl Grey

W	D	EPOXY		CHROME		WT.
		CAT. NO.	PRICE	CAT. NO.	PRICE	
2 Shelves, 42" Height						
36	18	HE-361835-2	◆ 291.00	HR-361835-2	480.00	43.0
36	24	HE-362435-2	◆ 328.00	HR-362435-2	531.00	49.0
42	18	HE-421835-2	327.00	HR-421835-2	510.00	46.0
42	24	HE-422435-2	346.00	HR-422435-2	543.00	53.0
48	18	HE-481835-2	◆ 315.00	HR-481835-2	00.00	49.0
48	24	HE-482435-2	352.00	HR-482435-2	555.00	56.0
60	24	HE-602435-2	◆ 412.00	HR-602435-2	635.00	77.0
3 Shelves, 42" Height						
36	18	HE-361835-3	◆ 362.00	HR-361835-3	632.00	54.0
36	24	HE-362435-3	◆ 409.00	HR-362435-3	699.00	62.0
42	18	HE-421835-3	327.00	HR-421835-3	718.00	46.0
42	24	HE-422435-3	436.00	HR-422435-3	744.00	67.0
48	18	HE-481835-3	◆ 398.00	HR-481835-3	699.00	62.0
48	24	HE-482435-3	445.00	HR-482435-3	735.00	72.0
60	24	HE-602435-3	◆ 502.00	HR-602435-3	855.00	100.0

CASTERS



Please Note: Casters must be used with No-Glide Posts (available on page 2).

DESCRIPTION	WHEEL DIA.	TREAD WIDTH	CASTER LOAD	CAT. NO.	PRICE	WT.
Poly Swivel	5	1 1/4	300	LC-1	14.50	2.0
Poly Swivel w/Brake	5	1 1/4	300	LC-2	17.00	2.5
Poly Fixed	5	1 1/4	300	LC-3	12.00	1.5

BUMPER

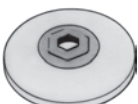

Ledge clips are used to affix back ledges to shelves when side ledges are not used.

DESCRIPTION	DIA.	CAT. NO.	PRICE	WT.
Rubber Bumper	5	RD-1	5.50	.5

ACCESSORIES



PLASTIC LABEL HOLDER

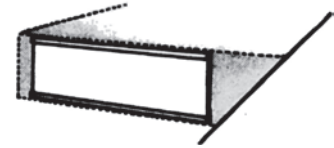

W	D	CAT. NO.	PRICE
3	1	PBM-3	.73
6	1	PBM-6	1.20

Plastic Label holder is attached by pressure sensitive tape to the front of the shelf.

POST EXTENDER

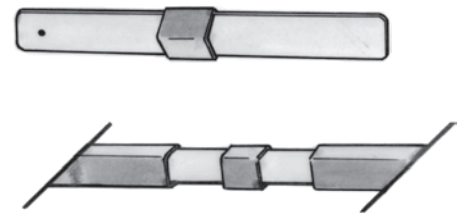

CAT. NO.	PRICE	WT.
PEXE	9.70	0.5

Used to extend post height to greater than 86³/₈".

BACK TO BACK TIES

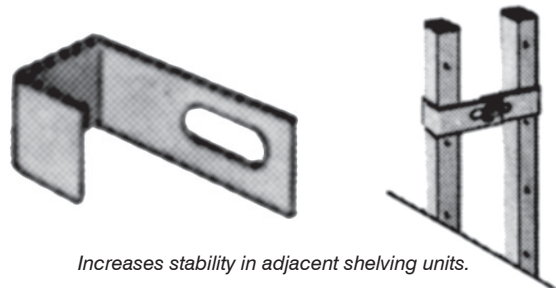

CAT. NO.	PRICE	WT.
BTBE	7.00	0.5

Increases stability in adjacent shelving units.

WALL TIES



CAT. NO.	PRICE	WT.
WTBE	2.90	0.5

FOOT PLATE

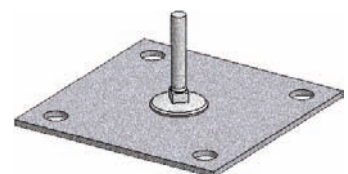

CAT. NO.	PRICE	WT.
LFP	7.00	0.2

Replaces leveling foot when bolting to the floor, or when larger foot is needed.

THREE SIDED CHANNEL BRACE



W	D	EPOXY		CHROME		WT.
		CAT. NO.	PRICE	CAT. NO.	PRICE	
24	18	CBE-2418	99.00	CBR-2418	118.00	8.1
24	24	CBE-2424	77.00	CBR-2424	95.00	8.9
30	18	CBE-3018	100.00	CBR-3018	118.00	9.0
30	24	CBE-3024	81.00	CBR-3024	100.00	10.0
36	18	CBE-3618	101.00	CBR-3618	119.00	10.0
36	24	CBE-3624	82.00	CBR-3624	101.00	11.0
42	18	CBE-4218	99.00	CBR-4218	123.00	11.0
42	24	CBE-4224	74.00	CBR-4224	94.00	12.0
48	18	CBE-4818	101.00	CBR-4818	114.00	12.0
48	24	CBE-4824	85.00	CBR-4824	98.00	13.0
60	18	CBE-6018	104.00	CBR-6018	117.00	13.9
60	24	CBE-6024	84.00	CBR-6024	97.00	15.0
72	18	CBE-7218	104.00	CBR-7218	128.00	14.8
72	24	CBE-7224	85.00	CBR-7224	102.00	16.0

SINGLE SHELF WALL BRACKET

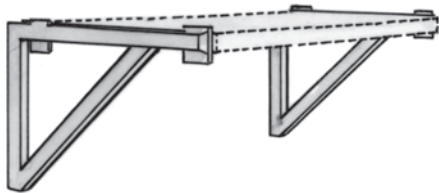

Mounting hardware not included.

DEPTH SIZE	EPOXY		WT.
	CAT. NO.	PRICE	
SETS OF TWO			
18	WBSE-18	214.00	10.7
24	WBSE-24	216.00	11.7
CENTER BRACKET ADD-ON			
18	CBASE-18	109.00	10.0
24	CBASE-24	116.00	10.0

DOUBLE SHELF WALL BRACKET

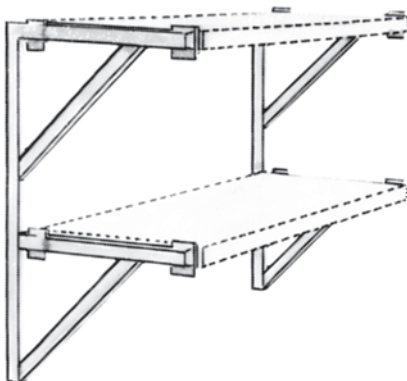

Mounting hardware not included.

DEPTH SIZE	EPOXY		WT.
	CAT. NO.	PRICE	
SETS OF TWO			
18	WBDE-18	287.00	16.8
24	WBDE-24	290.00	17.3
CENTER BRACKET ADD-ON			
18	CBADE-18	152.00	16.1
24	CBADE-24	161.00	16.1